

A Textbook of

Fashion Designing

Grade - IX

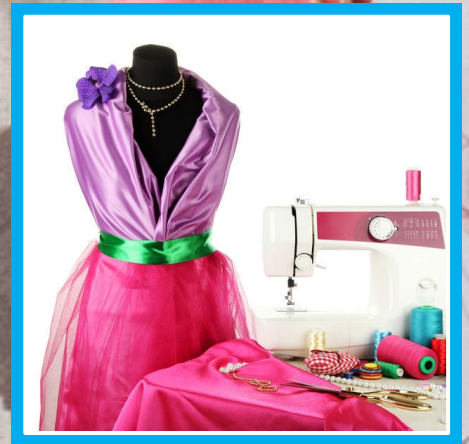

**National Vocational & Technical Training Commission
(NAVTTTC)**

A textbook of
Fashion Designing
Grade- IX



National Vocational & Technical Training Commission
H-9, Islamabad

Author: Mohni Saif, Director Academics for Faculty of Fashion & Textile Design @ Institute of Art, Design & Management.

Reviewers:

1. Ms.Mehwish Aisha, DACUM Facilitator
2. Ms.Ammara Maqbool, CBT expert, Freelance consultant Fashion Design, Rawalpindi
3. Ms. Sania Jamil, Freelance Consultant, Textiles, Rawalpindi
4. Dr Aneela Hassan, School Education Department, Punjab (Rawalpindi)
5. Ms. Zehra Habib, Education Officer, NCC Islamabad
6. Mr. Muhammad Asim, assistant Director, SS&C Wing, NAVTTC Islamabad
7. Mr. Shehzad Ahmad, Director, SS&C Wing, NAVTTC Islamabad

Designing: Gul Awan Printers, Blue Area, Islamabad.

Edition: 1st Edition, 2022

ISBN:

Publishers: National Vocational & Technical Training Commission

H-9, Islamabad.

Website: www.navttc.gov.pk, Phone:

All rights are preserved with the National Vocational and Technical Training Commission. No part of this book can be copied, translated, reproduced or used for guide books, key notes, helping books etc. without permission of NAVTTC.

Note: Names of Curriculum Developers will be part of curriculum document. In the book there will be names of reviewers only.

PREFACE

The education sector of Pakistan has achieved a milestone by developing a text book for Fashion Design for the first time in its history. The book is developed and reviewed by some of the most experienced educationists who are serving in this field for more than a decade, keeping in mind the basic knowledge to be inculcated to the students of matriculation. The knowledge will lay a staunch foundation for them to further excel in this field. At the same time, modern day educational approaches have been adopted throughout its development process. The exercises are designed in a manner that will challenge them to critically analyse the knowledge and develop a creative mind set. Author has specifically tried to give special attention to the fact that all the theoretically imparted knowledge is utilized practically through several sets of exercises and practical assignments. The book will definitely empower individuals in this field and will pave way for further excellence.

Executive Director
National Vocational & Technical Training Commission
(NAVTTTC)

Table of Contents

Chapter	Content	Page No.
1	Occupational Health, Safety and Environment	1
2	Intro to Fashion	39
3	Drawing-I	59
4	Basics of Design	75
5	Fashion Drawing-I	119
6	Glossary	141

OCCUPATIONAL HEALTH, SAFETY AND ENVIRONMENT

1

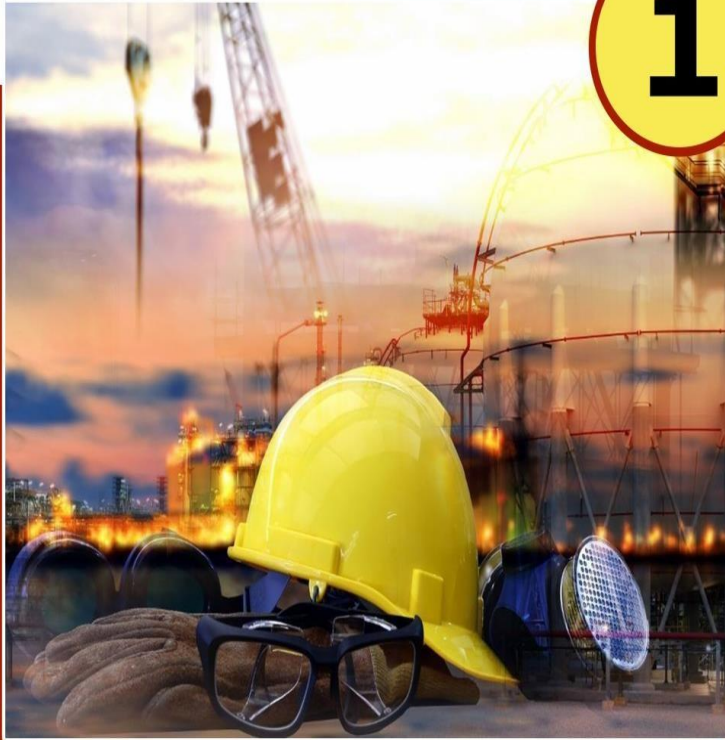

What is role of PPE Fashion Design?

Are the hazards different from risks?

Have you ever observed different types of fire?

Students Learning Outcomes:

After studying this unit students must be able to:

- ✓ know the hazards at Workplace
- ✓ define types of hazards
- ✓ explain Health & Safety equipment and materials
- ✓ identify any potential hazards at workplace and take appropriate action to minimize the risk using appropriate Health & Safety equipment
- ✓ explain procedures to clean and store tools/equipment after use.
- ✓ understand Health and Safety Regulations
- ✓ identify general safety rules in Fashion Industry
- ✓ organize workplace as per OHS standards

Occupational Health, Safety and Environment

Occupational safety and health (OSH) is defined as the science of the anticipation, recognition, evaluation and control of hazards at workplace. These hazards can affect the health and safety of workers.

Importance of Occupational Health and Safety:

Workplace is like a home as most workers spend at least eight hours a day in the there. It can be an office, factory, school, university, etc. Therefore, work environments should be safe and healthy. Workers face multiple health hazards on daily basis, like: dusts, gases, noise, vibration, extreme temperatures, infections, injuries, etc.

1. Hazards at Workplace:

Hazard at workplace indicates a situation in the workplace that could cause injury or adverse health effects for people and could damage the equipment and environment.

Types of Hazards:



Do You Know?

Workplace:

Workplace refers to a place or environment where people work e.g. office, factory etc.

Hazard:

Hazard is a general term to tell about danger or risk. Anything that is dangerous or provides risk to health or causes illness is hazardous.

Risk:

Risk is the possibility that a person may get harmed or suffers adverse health effects if exposed to a hazard.

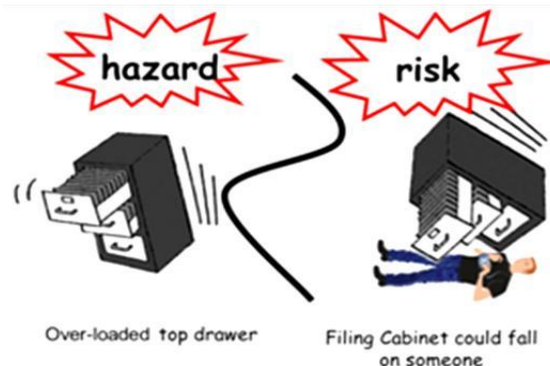

Following are the types of workplace hazards:

1. Safety Hazards

Safety hazards are the most common workplace risks. They include:

- spills like cords, rough edges of floor mats, etc.
- falls like working from heights, ladders, roofs, etc.
- Unsafe and moving machinery parts that a worker can accidentally touch.
- Electrical hazards like ragged cords, missing ground pins, improper wiring
- Confined spaces, etc.



2. Biological Hazards:

Biological hazards are also known as biohazards. They include:

- Blood and other body fluids
- Fungi/mold
- Bacteria and viruses
- Plants
- Insect bites
- Animal and bird droppings



3. Physical Hazards

Physical hazards are not always something that you can see or touch. Physical hazards can be aspects within the environment that can harm the body without touching it.

They include:

- Radiations (microwaves, radio waves, etc.)
- High exposure to sunlight/ultraviolet rays
- Extreme Temperature (hot and cold)
- Loud Noises



4. Ergonomic Hazards

Ergonomic safety hazards occur when the type of work, body positions, and working conditions put a strain on your body. They are difficult to identify because you do not immediately recognise the harm they are doing to your health. They include:

- Poor visual conditions/lighting
- Improperly designed tools or work areas
- Poor body postures
- Improper lifting or reaching
- Repetitive or awkward movements



5. Chemical Hazards

Chemical hazards exist when you are exposed to any chemical preparation at workplace. These chemicals can be in solid, liquid or gaseous form. Some are safer than others, but to some workers who are more sensitive to chemicals, even common solutions can cause illness, skin irritation, or breathing problems. They include:

- Liquids (cleaning products, paints, acids, etc.)
- Vapors and fumes
- Gases
- Flammable materials (gasoline, solvents, explosive chemicals, etc.)



Activity:

- ❖ Think about places or workplaces with which you are familiar (factories, stores, kitchens, offices, etc.). List down the health and safety hazards in all these various workplaces and write in a chart with three columns like this:





SAFETY HAZARDS	CHEMICAL HAZARDS	OTHER HAZARDS

2. Standard Operating Procedures (SOPs):

You must read the work processes, Standard Operating Procedures (SOPs) and work procedures to understand the hazards and risks at workplace. SOPs are step-by-step instructions that act as guidelines for work processes. SOPs are shaped for workers to operate in a formalised and coordinated way which increases productivity and reduces the risk of errors.



Controlling the Hazards/Risks

Health and safety are regulations and procedures intended to prevent accident or injury in workplaces or public environments. It focuses on Safety of individuals, Safety of Equipment and Safety of Environment. This is also known as 3S concept of Health & Safety. The following points provide identification of hazards and precautions against injuries/illnesses in office environments in line with the 3S concept:

Working Environment Hazards	Precautions
<ul style="list-style-type: none"> • Electrical: cable related issues, electric shocks, power failure, short circuit, sparks etc. • Housekeeping: poor cleanliness, arrangement of equipment, proper storage, space allocation, etc. • Equipment/ Sharp edges/ hot surfaces: injuries, electric shock, cuts, wounds and burns, etc. • Cables: trip hazard, short circuit, overheating of cables etc. • Staff unaware of emergency procedures: evacuation failure, death toll may rise (severe scenario), severe consequences. • Poor ventilation: smoke and odor. • Temperature variations: 	<ul style="list-style-type: none"> ✓ Report any damaged power cords or power points to supervisors or managers. ✓ Minimise the use of power boards and extension cables and ensure they are not across walkways. ✓ Do not attach numerous extension cords or power boards together. ✓ Ask for more power points to be installed. ✓ Floors, walkways, stairs and storage areas should free from obstructions ✓ Emergency exits should not be blocked. ✓ All floor surfaces should be properly maintained and, if required, covered with non-slip material. ✓ Sufficient lighting should be provided in all areas. ✓ Step stools or step ladders should be used to reach items above shoulder level. Do not use chairs or tables for reaching the items. ✓ Filing cabinets and bookcases should be stabilized and aligned to prevent their falling over. ✓ Files or equipment should not be stacked on top of high cupboards or cabinets. ✓ Maintenance of all equipment should be observed periodically. <div style="display: flex; justify-content: space-around; align-items: center; margin-top: 20px;">      </div>

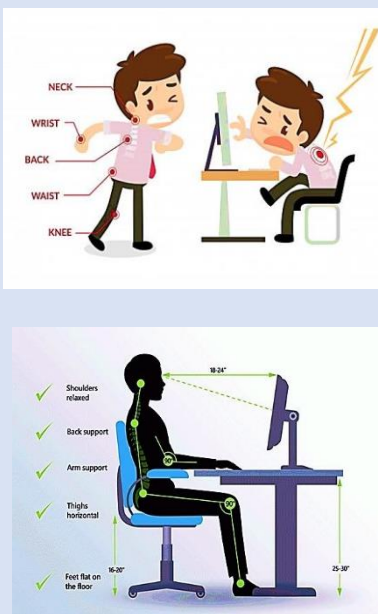
<p>□ equipment damage, illness of employees. Poor lighting: poor visibility, eye strain, inability of color identification, eyesight may get weaker, etc.</p>	<ul style="list-style-type: none"> ✓ Shelves or file cabinets should not be overloaded and heavy items should be stored at low levels. ✓ Fans and heaters should be provided is not air-conditioned. ✓ Suitable clothing for the weather conditions should be worn: Light clothing on hot days and warmer clothing for cold days. ✓ Be aware of emergency procedures for the area. ✓ Receive appropriate training for the tasks to be performed. 	
--	---	---

Hazards Working with Computers	Precautions
<ul style="list-style-type: none"> • Posture: excessive reach, awkward position in seating, slouching, etc. • Seating: excessive duration in a seated position. • Workstation: incorrect setup, poor heights, unavailability of proper lighting, etc. • Glare: reflection of lights in the screen, light source directly in the vision while facing the screen etc. • Repetitive movements: use of keyboard and mouse for long, eyestrain, sitting in one position etc. 	<ul style="list-style-type: none"> ✓ Adjustable chairs, desks and ergonomic accessories such as document holders are to be used. ✓ Take breaks or do some stretches. ✓ Discuss the situation with supervisor. ✓ Adjust the lighting or seating where glare is not in direct contact with your eyes. 

Office Equipment Hazards	Precautions	
<ul style="list-style-type: none"> • Poor ventilation: Smoke, odor, chest infections etc. • Poor Housekeeping: Cluttered spaces, poor storage, exit blockage, poor cleanliness, illness, hygiene issues etc. • Workbenches: Incorrect heights, poor postures, body aches, muscular pains etc. • Inks and toners: leakage, chest infections, hygiene issues etc. 	<ul style="list-style-type: none"> ✓ Areas should be kept clean and tidy and that cables are kept clear of walkways. ✓ Workbenches should be at waist level. ✓ Clear the exits. ✓ Employees must be trained in the operation of equipment. ✓ Ensure plenty ventilation for humid areas. ✓ Moving parts of the machinery should be covered to prevent people having access to it moving parts during operation. ✓ While machines are in work, do not insert or attach anything related nonrelated to it. ✓ Equipment such as shredders and laminators should not be used with loose clothing or jewelry. People with long hair must tie it back. ✓ Sharp objects should not be pointed towards self or others. 	<div style="text-align: center; border: 1px solid black; padding: 5px; margin-bottom: 10px;">BEFORE</div>  <div style="text-align: center; border: 1px solid black; padding: 5px; margin-bottom: 10px;">AFTER</div>  <div style="text-align: center; border: 1px solid black; padding: 10px; margin-top: 20px;">  </div>

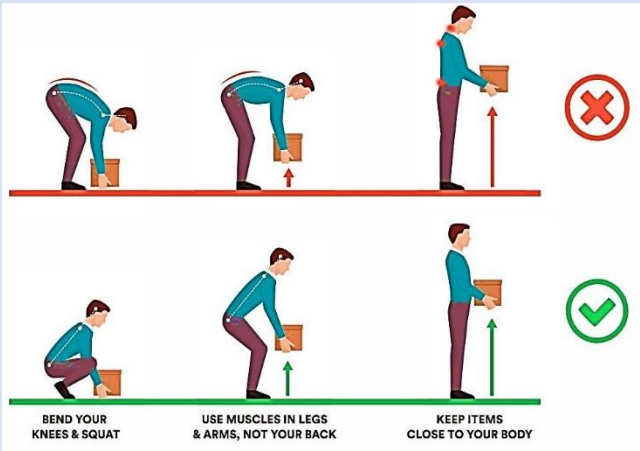
Moving and Handling Items Hazards	Precautions
<ul style="list-style-type: none"> • Lifting heavy items: Poor postures, back bone related issues, muscular pains etc. • Repetitive lifting: Strain on muscles, weakness, dehydration etc. • Using incorrect techniques: Sliding, pulling/pushing, body adjustments etc. 	<ul style="list-style-type: none"> ✓ Rest breaks, exercise, and task rotation ✓ Manual handling aids provided e.g. Trolleys ✓ To lift heavy object, one should sit, and lift it up by putting weight on his legs. <div data-bbox="967 380 1414 695" style="text-align: right;">  <p>DANGER</p> <p>HEAVY OBJECTS LIFT WITH CARE</p> </div> <div data-bbox="613 751 1248 1199" style="text-align: center;">  <p>BEND YOUR KNEES & SQUAT USE MUSCLES IN LEGS & ARMS, NOT YOUR BACK KEEP ITEMS CLOSE TO YOUR BODY</p> </div>

Safety Signs and Symbols

Safety signs and symbols are important safety communicating tools. They help to indicate various hazards that present at workplace. At the same time, they warn workers to always keep watching out for those hazards by giving required information and safety instructions. Having safety signs and symbols at workplace is essential. A visible instruction from a safety sign gives clear indication and lessens the likelihood of accidents to employees and non-employees, and therefore creates a safer working environment.

Safety signs are categorised into four areas i.e. Prohibition, Warning, Mandatory and Emergency.

□ Prohibition Signs:

A sign prohibiting behavior likely to increase or cause danger (e.g. “No access for unauthorized personnel”). These signs are used for “Do Not” commands. For example – to indicate that smoking is not allowed in a particular area. In the workplace they should be used to reinforce instructions prohibiting dangerous activities.

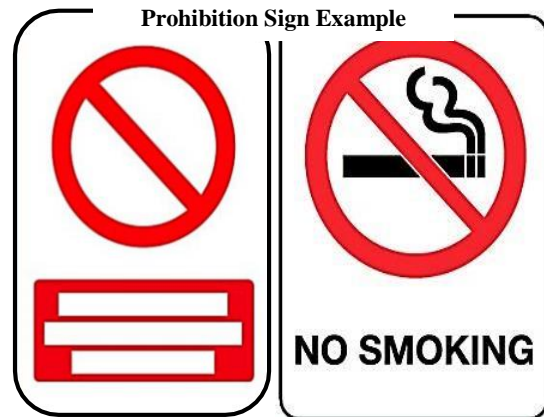

□ Warning Signs:

A sign giving warning of a hazard or danger (e.g. “Danger: High Voltage”). These signs are used to make people aware of a nearby danger. For example – Wet or Slippery Floor, Electrocutation Danger etc. Warning signs of a particular hazard appear as a black band in the shape of an equilateral triangle. The background within the band is yellow with the imagery indicating the type of hazard in black, positioned centrally on the sign.



□ Mandatory Signs:

A safety sign prescribing specific behavior (e.g. “Personal Protective Equipment Must Be Worn”). These signs are used to indicate actions that must be carried out in order to comply with standardized requirements for example, self-closing fire doors that must be kept closed to comply with the fire risk assessment should be labeled with “FIRE



DOOR KEEP SHUT”. Signs indicating mandatory requirements consist of a blue circle with the pictogram or text in white positioned centrally.

□ Emergency Signs:

A sign giving information on emergency exits, first aid, or rescue facilities (e.g. Emergency Exit). These information signs are used to indicate escape routes, emergency exits and first aid equipment. Safe condition signs appear as a green rectangle or square with the imagery or text in white positioned centrally.

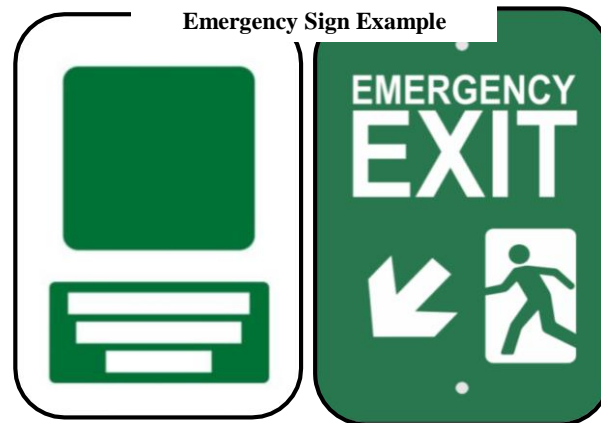

Do You Know?

Safety Signs are crucial in any work environment. The primary importance of displaying Safety Signs is to prevent injury and ensure staff and visitors are well aware of the possible dangers and hazards ahead in certain situations and/or environments.

Yellow / Amber: Warning sign - Be careful; take precautions; examine

Blue: Mandatory sign - Specific behavior or action; wear protective equipment

Green: Emergency / First-aid sign - Doors; exits; escape routes; equipment and facilities

Work Equipment and Health & Safety Requirements







Work equipment is defined as any machinery, appliance, apparatus, tool or installation for use at work. The scope of work equipment is therefore extremely wide. Work equipment is found and used in every department in the fashion and textile industry. Every year, there are a number of accidents from using work equipment. Many are serious and some are fatal. A number of health and safety incidents take place due to equipment being used in a way that it was never designed or intended to be used in.





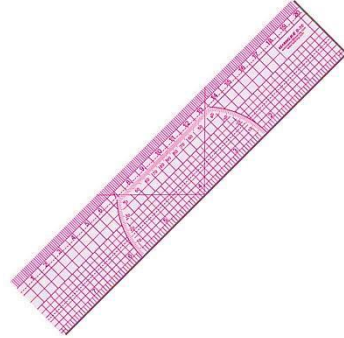





Do You Know?



Occupational Health and Safety (OHS) is about protecting workers from harm at work. This includes death & injury (safety) and disease & illness (health).

Tools, Equipment and Machines for Fashion Designing/ Apparel Industry

Understanding of tools, equipment and machines in the workplace provides an upperhand in analysing the hazards and risks related to each item. Tools, equipment and machines required for fashion and dressmaking are given below:

<p>Tailor's art curve</p> 	<p>L-scale</p> 
<p>French curve</p> 	<p>Japanese Scale</p> 
<p>Pattern drafting table</p> 	<p>Red and blue pencils</p> 
<p>Tracing wheel</p> 	<p>Tailors pins</p> 

<p>Pin holders</p> 	<p>Scissors</p> 
<p>Pushpins</p> 	<p>Scotch tape</p> 
<p>Notcher Awl</p> 	<p>Measuring tape</p> 
<p>Tailor's chalk</p> 	<p>Thimble</p> 
<p>Sewing Needles</p> 	<p>Sewing Machine Needles</p> 

 <p>Seam Ripper</p>	 <p>Calico</p>
 <p>Cutting Table</p>	 <p>Mannequin</p>
<p>Sewing Machines</p> 	

Understanding the potential hazards in fashion design/ Apparel industry is necessary since many issues related to health and safety can be dealt if you are aware of the potential hazards of the daily activities.

SNO	Activities Description	Potential Hazard
1.	Operating Stitching Machine	Sharp edges, knife blade, scissor, pins, eye strain and operator error or inattention with the potential of causing puncture wounds and cuts to the finger and/or electrocution.
2.	Hand Sewing	Sharp Edges, pins, scissors, punctures, wounds and cuts etc.
3.	Pattern Making & cutting	Sharp Edges, knife blade, scissors, pins, body posture, paper cuts etc.
4.	Ironing of Clothes	Burn hazards, electrocution.
5.	Working with fabrics & fibers	Respiratory hazards

General Safety Rules in Fashion Design Industry

While working within the fashion designing field, you must know the general safety rules to avoid unnecessary health and safety hazards:

- Ensure that long hair is tied back and beards are trimmed to prevent them being caught in the moving parts of machinery.
- Remove any jewellery that dangles loosely from you, including watches, necklaces, bracelets and earrings.
- Do not wear loose or flared clothes. Wear tight/semi-fitting clothes as loose or baggy clothing can get caught in machinery.
- Do not point sharp objects towards others.
- Keep sharp or pointy objects away from eyes, mouth and face.
- Do not leave the fabric shears or scissors open.
- Wear appropriate shoes all the time.



Long Hair Entangled Hazard



Loose Jewelry Hazard

- Use the tools for the purpose they are intended to.
- When sewing on the machine keep your hands away from the needle.
- Do not stick fingers with the pins when sewing. □ Do not sew over the pins.
- Do not hold pins in your mouth, use a pin cushion or holder.
- Do not use dull or bent needles.
- Do not throw needles on the floors or tables.
- Do not smoke, eat or drink in the work spaces.
- Make sure that the wires are not tangled and are not in the walking pathways.
- Use mesh gloves to prevent accidental injury when using powered cutting equipment.
- Do not talk when operating machinery. If you need to talk, turn the machine off.
- Turn off the machines before changing the needles/ cutters.
- Follow correct manual handling procedures when you need to lift or move heavy rolls of fabric or cutters onto the cutting table
- Divert people traffic from the cutting tables, using clearly marked paths.
- The cutting table should be stable and at a height appropriate for the cutter - 90cm is an average height.
- The work area floor should be non-slip and cleared of all fabric scraps and obstacles.
- Make sure there is good ventilation in the cutting room because cutting produces a lot of dust and lint, and some fabrics contain pesticides.
- Use dust masks when working in the cutting room as cutting produces a lot of dust and lint, and some treated fabrics contain chemicals.



Loose Clothing Entangled Hazard



Correct Method of Storing Pins



(Do not Use) Broken/Bent Needles



Fallen Needles Hazard

- Lay a single smooth sheet of paper between the fabric lay and the cutting table.

This lets you move the fabric accurately and safely.

- Use weights or clamps to keep the fabric from moving and to maintain the accuracy of cutting.

- Be careful when ripping out seams with seam ripper.

Be sure to "rip" seams away from you.

- Put the seam-ripper's cap back after use.
- Ensure safe handling of equipment.
- Stop using scissors while looking away.
- Always cut away from your body or body parts.
- Always pass a pair of scissors handle first to another person.

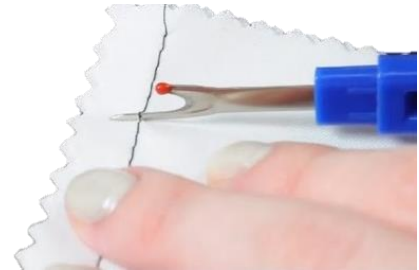

Ripping Seams (Away from you)



Incorrect VS Correct way of Passing Scissors

- Use thimble while sewing.
- Store the tools and equipment properly after use.
- Use Personal Protective Equipment wherever necessary.



Use of Thimble

Above mentioned generic health and safety rules ensure a safe working environment.

Activity: Find and List down the Hazards in the sewing scene and the risk they could cause

- ✓ Describe the hazards while using Sewing Machine?
- ✓ Describe the hazards and risk factors included while ironing the clothes.
- ✓ List down at least Ten safety rules while working with Fashion design/Apparel industry tools, equipment and machines. Also list down the hazards and risks if these safety measures are not observed.

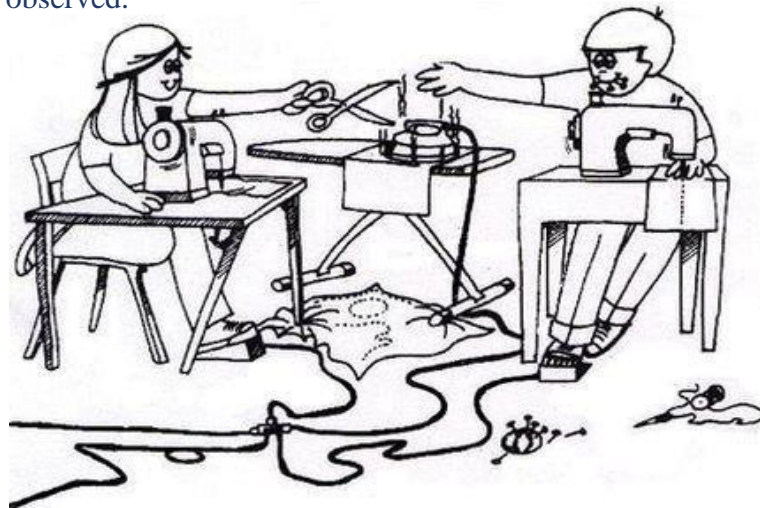

Personal Protective Equipment for Fashion Design / Apparel Industry

Personal protective equipment or PPE is specialised clothing or equipment, worn by an employee for protection against infectious or hazardous materials. PPE is used to create a protective barrier between a worker and hazards in the workplace. PPE includes equipment such as chemical resistant gloves, safety shoes, hard hats, safety glasses, respirators, and clothing such as gowns and aprons etc. PPE must be worn to minimise exposure to

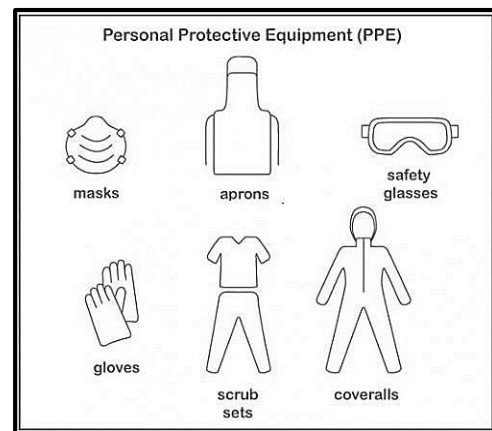

PPE Kit

hazards that cause serious workplace injuries and illnesses. There are 6 types of PPE in any industry:

- **Head Protection:**

Head Protection is required for everyone working in areas where there is potential danger of head injury from impact, electrical shock or burns, or falling or flying objects. Examples of head protection PPE



include helmets, hard hats, bump caps, guards etc. Such protective helmets are designed to absorb the shock of a blow and resist penetration by falling or flying objects.

- **Hearing Protection:**

Hearing protection is vital for those working in an environment with high-sound levels. Examples of hearing protection include earplugs, noise meters, acoustic foam, and communications sets. Plain cotton is never



an acceptable protection device as the equipment should provide an adequate level of protection, hygiene, and comfort to its user.

- **Eye and Face Protection:**

Eye and face protection is necessary when someone is exposed to eye or face hazards from liquid chemicals, acids, chemical gases, heat, light radiation, and flying particles. Examples of eye and face PPE include visors, over specs, eye and face shields, eyewear accessories, safety glasses, and goggles.



- **Respiratory Protection:**

Respiratory protection covers a broad range of equipment that should be used when workers may come into contact with large amounts of harmful dusts, fogs, mists, fumes, vapors, powders, or gases. This type of equipment may include face masks, protective hoods, respirators, helmets, etc.



- **Hand Protection:**

Hand protection equipment is necessary to protect workers against cuts, scratches, punctures, abrasions, chemical burns, thermal burns, and harmful temperature extremes etc. Common activities that may require hand protection equipment include working in hot or cold environments, manually handling sharp objects, and working with hazardous chemicals. Hand protection equipment may include leather, latex, canvas, metal, coated fabric, and chemical-resistant gloves.



- **Body Protection:**

Body protection equipment is used to protect workers from Heat, chemical or metal splash, spray from pressure leaks or spray guns, contaminated dust, impact or penetration, excessive wear or entanglement of own clothing, sharp objects etc. Body protection equipment may include aprons and overalls etc.



Interesting Information

The overall objective of Occupational Safety and Health is to prevent diseases, injuries, and deaths that are due to working conditions. Occupational safety deals with all aspects of physical, mental and social health and safety in a workplace. It is the umbrella for company's efforts to prevent injuries and hazards in all work environments.

Activity:

- ❖ List down Personal Protective Equipment used in Fashion/Apparel industry. Also describe their uses.
 - ❖ List at least ten workplace hazards, related PPE and precautions to avoid hazards
-
- ✓ Demonstrate the use of Personal Protective Equipment (PPE) for specified working conditions/ different scenarios keeping in mind Fashion/Apparel industry?
 - ✓ Visit stitching lab of your institute and identify potential hazards. List down PPE available to work there. Also list the PPE required, if not available, to work there.
 - ✓ Visit Electrical room or Power lab of your institute and identify potential hazards. List down PPE available to work there. Also list the PPE required, if not available, to work there.
 - ✓ Demonstrate working on 400V live circuit using appropriate PPE











Working Procedure of Fire Extinguisher

Every workplace requires fire extinguisher(s), and every worker should know where the near one is.

A single fire extinguisher does not work on all types of fire. There are different types of fire extinguishers as there are many different classes of fire. To ensure the safety of workplace you need to ensure the installation of appropriate extinguisher, relevant to the possible fire hazards for your workplace.

Before understanding working functionality of Fire Extinguisher you need to understand fire chemistry. Fire is classified into five different classes:



Colour /Symbol	Image	Fire Classifications
		Class A: Freely burning, combustible solid materials such as wood or paper
		Class B: Flammable liquid or gas
		Class C: Energised electrical fire (energised electrical source serves as the ignitor of a class A or B fire – if electrical source is removed, it is no longer a class C fire)
		Class D: Metallic fire (titanium, zirconium, magnesium, sodium)
		Class K: Cooking fires – animal or vegetable oils or fats

Interesting Information

Regardless of fire type, there will always be the same four elements present:

- Fuel
- Heat
- Oxygen
- Chain Reaction

Types of Fire Extinguishers



Foam Fire Extinguisher:

- ✓ Used for Classes A and B
- ✓ Dangerous if used for Class



Water Fire Extinguisher:

- ✓ Used for Class A
- ✓ Dangerous if used for Classes E and F



Carbon Dioxide Fire Extinguisher:

- ✓ Used for Classes B
- ✓ Dangerous if used for Class A and C



Powder Dioxide Fire Extinguisher:

- ✓ Used for Classes A, B & C
- ✓ Dangerous if used for: Class K

Activity: Describe the Types of Fires and Extinguisher for each class

CLASS OF FIRE	TYPE OF FIRE	APPROVED FIRE EXTINGUISHER
  Ordinary Combustibles		
  Flammable Liquids		
  Live Electrical Equipment		
  Combustible Metal		
  Cooking Equipment		

Pass Concept:

All extinguishers have printing instructions on them. But what you need to remember is an easy acronym: P.A.S.S.

- **P: PULL** the safety PIN from the handle
- **A: AIM** at the base of the fire
- **S: SQUEEZE** the trigger
- **S: SWEEP** from side to side



Activity:

❖ Answer the following questions:

1. Describe the Class A fires. Give some examples
2. What are Class B fires, elaborate with examples
3. Distinguish between Class C and Class D fires. Give separate examples of the both.
4. What are Class K Fires, give examples

Activity:

❖ Demonstrate fire -fighting by operating Fire Extinguisher using PASS concept

Risk Assessment & Control Process

Risk is the possibility that a person may be harmed or suffers adverse health effects if exposed to a hazard. Risk assessment and control is in relation to hazard identification. Hazard identification is the first step to conduct risk assessment and hazard control process. In other words, it is the process where following steps are included:

Step 1: Identify the hazards

Step 2: Decide who might be harmed and how

Step 3: Evaluate the risks and decide on precautions

Step 4: Record your findings and implement them

Step 5: Review your assessment and update if necessary

Do You Know?

Hazard identification, risk assessment and control are the responsibility of organization however, as an employee of the company it is your moral duty to identify hazard related to your work, assess risks and take precautions (after discussing it with your supervisor/manager) to control it.

Hazard identification, risk assessment and control can be done by filling out a table/chart. A sample chart is given below that may help in hazard identification and risk assessment:

Risk Assessment Chart (Example)				
Area of Work			Workstation	
Task/ Scenario	Hazard	Risk	Priority	Control
Working on a Computer	Power Failure	<ul style="list-style-type: none"> ▪ Data Loss ▪ Equipment failure ▪ Software failure 	High	<ul style="list-style-type: none"> • Install UPS
	Low/High Voltage	<ul style="list-style-type: none"> ▪ Equipment Failure ▪ Sparks 	High	<ul style="list-style-type: none"> • Install Power stabilizers (talk to manager/supervisor)
	Electric Shock	<ul style="list-style-type: none"> ▪ Electrocution ▪ Faintness ▪ Heart failure ▪ Death ▪ Injury/Burn 	Very High	<ul style="list-style-type: none"> • Power off and unplug electric Items before maintenance • Insulated cables. • Grounded electrical equipment • Circuit Breaker installation

	Tangled Cables	<ul style="list-style-type: none"> ▪ Tripping of individuals ▪ Power disconnection due to tripping as it may cause unplugging of cables ▪ Equipment failure ▪ Data loss ▪ Overheating ▪ Sparks 	Medium	<ul style="list-style-type: none"> • Jacketed cables • Manage cables to keep away from traffic zone. • Periodically Check for overheating/ burn purposes
	Poor Ergonomics	<ul style="list-style-type: none"> ▪ Muscular pains ▪ Body aches ▪ Head aches ▪ Eye strain ▪ Fatigue ▪ Backbone issues 	High	<ul style="list-style-type: none"> • Following ergonomic workspace guidelines
	Sockets	<ul style="list-style-type: none"> ▪ Sparks ▪ Burns ▪ Shock ▪ Fire trigger 	Low	<ul style="list-style-type: none"> • Periodic check • Circuit Breaker installation

Activity:

- ❖ Prepare Risk Assessment chart for:
 - Spilled water near a water dispenser
 - Making and cutting of patterns
 - Working in the stitching lab on a sewing machine
 - Ironing the Clothes

Risk assessment and control can be done by using Look, Think and Do procedure:

- ✓ **Look:** Look out for dangers.
- ✓ **Think:** How you can protect yourself, others and workplace from potential dangers or risks.
- ✓ **Do:** Apply strategies to remove or minimize the danger/risk.

Occupational Safety & Health (OSH) Regulations in Pakistan

Occupational Safety and Health (OSH) is a multidisciplinary field that shows concept of intended working culture, reflection of the essential value systems adopted by the organisations. This discipline has been defined by World Health Organization (WHO) and International Labour Organization (ILO) as “all aspects of health and safety in the workplace with strong focus on prevention of hazards, a state of complete physical, mental and social well-being”. The main objectives include maintenance and promotion of workers’ health and working capacity, improvement of working environment and work to become beneficial to safety and health, promotion of health and safety at workplace. There are a number of regulations and laws in Pakistan which promotes health and safety within work-places such as:

- ✚ Electricity Act, 1910 and Rules, 1937
- ✚ Workmen compensation Act, 1923
- ✚ Factories Act, 1934 (Chapter 3)
- ✚ Hazardous Occupations Rule, 1963 and 1978
- ✚ Provincial Employees Social Security Ordinance, 1965
- ✚ Pakistan Environmental Protection Act, 1997 (Hazardous Substance Rules, 2003)
- ✚ Punjab Occupational Safety and Health Law, 2016
- ✚ Pakistan Occupational Health and Safety Act, 2018
- ✚ The Punjab Occupational Safety And Health Act, 2019

The main objectives of all the above laws and regulations include:

- Protecting workers and other persons against harm to their health, safety and welfare through the elimination or minimization of risks arising from work
- Providing for fair and effective workplace representation in relation to work health and safety
- Promoting improvements in health and safety practices at work and assisting persons conducting businesses or undertakings and workers to achieve a healthier and safer working environment
- Providing a framework for continuous improvement and progressively higher standards of health and safety at work

Do You Know?

Laws, legislations and regulations are there but their implementation and enforcement is weak within Pakistan.

The common health and safety provisions under all the rules, regulations and acts are:

- Cleanliness
- Disposal of wastes
- Ventilation and temperatures
- Dust and fumes
- Over-crowding of workspaces
- Work-place lighting conditions
- Drinking water
- Washrooms and urinals
- Precautions against contagious or infectious diseases
- Fire safety and precautions
- Working on machines
- Electric Safety
- Floors, stairs and means of access
- Personal Protective Equipment
- Safety of manufacturing processes and machinery

Activity:

- ❖ What are some common health and safety provisions under the health and safety regulations in Pakistan?
- ❖ What are some main objectives of the Health and Safety regulations within Pakistan?

Important Definitions

- **Occupational Safety & Health (OHS):** OSH or OHS (Occupational Health and Safety) is a multidisciplinary practice dealing with all aspects of health and safety in the workplace, with a strong focus on preventing workplace hazards. In Other words, Occupational health and safety is concerned with protecting the safety, health and wellbeing of people occupied in work or employment.
- **Accident:** an unfortunate incident that happens unexpectedly and unintentionally, typically resulting in damage or injury or an event that cause harm to any person.
- **Dangerous Incident:** an incident in relation to a workplace that exposes a worker or any other person to a serious risk to a person's health or safety.
- **Harm:** Illness and/or Injury ○ **Hazard:** any activity, occurrences, processes, situations, or substances that is an actual or potential cause or source of harm
- **Risk:** the probability of occurrence of injury or damage; **Safe:** means free from any hazard.
- **Workplace:** Any premise where work is carried out, by one or more persons and includes premises used for the storage of tools, machinery, equipment or substance.

Organising workplace as per OHS standards

Getting your space organized can increase your productivity and minimize your stress level. Once you establish a systematic method of keeping things in order, you will save time and energy. Five minutes spent planning and organizing at the beginning and end of each workday will keep things under control.

- **Office Cleansing:** De-clutter (free) your workspace from extra items. Empty the drawers, shelves and desktop. Throw away the waste material. Get rid of everything that you don't need or want.
- **Collect and Redistribute:** Gather up every item that is not where it belongs. Put it where it does.
- **Establish work “zones”:** Decide the type of activity that happens in each area of office. You will probably have:
 - A main workspace (most likely your desk).
 - Reference area (filing cabinet, shelves, binders).
 - Supply area (closet, shelves or drawers).
 - Place the appropriate equipment and supplies in the proper area as much as possible.
- **Proximity:** Close proximity means the nearness or closeness between equipment and items. Position the equipment and supplies that you use most within reach. Things that you rarely use can be stored or put away.
- **Label Things:** Labeling things and files/folders is a good way to maintain your workspace. Follow the given tips for labeling:
 - Choose a label maker that's simple to use.
 - Take the time to label shelves, bins, baskets drawers. Not only will it remind you where things go, but it will also help others who may have a need to find, use, or put away anything in your workspace.
 - If you have paper work included in your office work, make separate files and label them accordingly i.e. customer name, order name, date, deadline etc.
- **Filing System:** This is digital age and the need to store paper files has decreased. Review your digital files; there might be some files that are outdated and no longer in use. Back up old files and data and remove them from your system as they may be consuming your system memory. Store the paper work, if included in office work, into the shelves or storage cabinets properly.

Good to Remember

Before throwing anything, discuss with your supervisor or manager, as they might need that specific thing or file in the long run. If they want it in the long run, ask them the appropriate place to store it.

- **Meeting Folder:** Meetings folder should be maintained and put all “items to be discussed” in there along with items that need to be handed off, reports that need to be given, etc. It’ll help you be prepared for meetings and save you stress in the event that a meeting is moved up.
- **Clear the Desk:** Organize and maintain your desk/workstation by:
 - Remove everything, clean it thoroughly and put back only those items that are essential for daily use.
 - Put items that are not in regular use in store or storage shelves.
 - Organize your desktop.
 - Use desktop organizers or containers to organize the items on your desk.
 - Use trays for papers and containers for smaller items.

Good to Remember

Straighten your desk: At the end of the day do a quick straighten, so you have a clean start the next day



Example of Organized Sewing Workspace (Industrial)



Example of unorganised Sewing Workspace (Domestic)

- **Organise Drawers:** Organizing drawers are also an important part. Do not think that drawers are a hiding spot and you can fill it with everything that is not in use. Remember that drawers are made to place things in an order so whenever you require them, they are in easy approach. Cluttered drawers may give you a hard time in finding the thing you need and it wastes your time. Organize your drawers by:

- Putting items used together in the same drawer space, stamps with envelopes, sticky pads with notepads, etc.
- Using drawer organizers for little items – paper clips, tacks, etc.
- Using a separate drawer for personal items.



Example of Organized Sewing Workspace (Domestic)

- **Clear Piles:** Piled up paperwork and files gives an untidy look and shows an irresponsible behavior. Follow these steps to give a tidy look by clearing the piled work:
 - Go through the pile (a little at a time if necessary).
 - Put it in the appropriate place or dump it (if no further in use).
- **Mail:** Mails are an important part of being an employee. You get mails from your clients, managers, supervisors or colleagues who are working with you on a same project. It is a best practice to sort mail as soon as you get it. As it digital era, emails are fastest way of correspondence. Take some time out and read the emails on daily basis. Reply the emails that need your attention.
- **Storage Boxes:** Storage boxes are really helpful in storing unwanted paperwork, files and folders etc. Use storage boxes to keep archived files and get them out of your current file space. Label the storage boxes so it would be easy to locate them later. Storage boxes can also be used for storing.



Interesting Information

- **Discard Dates:** Assigning discard dates to paperwork or files, documents and folders you can maintain a pile- free work area. You don't need to keep every piece of paper indefinitely. Mark on files or documents when they can be taken away or thrown. Some legal or financial documents must be kept for specified length of time. Make sure you know about the requirements of documents before throwing them away.

Key Points

There are several types of hazards that need to be considered at workplace. Health & Safety equipment and materials should be employed for safe working.

Procedures to clean and store tools/equipment after use should be followed in industry.

The OHS standards are helpful in organising workplace.

Personal Protective Equipment (PPE) are very helpful in controlling workplace hazards.

It is very important for a worker to understand safety signs to avoid accidents.

Web Links

<https://safetymanagement.eku.edu/blog/environmental-hazards-in-the-workplace//>

<https://support.ce-check.eu/hc/en-us/articles/360021707072-8-Types-ofPersonal-Protective-Equipment-PPE->

https://www.hsa.ie/eng/Topics/Managing_Health_and_Safety/Safety_and_Health_Management_Systems/

Tick (✓) the correct option

1. **OHS stands for _____.**
 - a) Occupational Health & Safety
 - b) Over Heated System
 - c) Occupational Heat signals
 - d) Occupational Hearing Strength

2. **Electrical hazard is a hazard related to _____**
 - a) Gas leaks
 - b) Electricity
 - c) Ergonomic
 - d) Heavy Equipment

3. **Green colour coded fire extinguishers are used to extinguish _____ class of fires.**
 - a) B
 - b) A
 - c) K
 - d) C

4. **SOP stands for:**
 - a) Standard Operating Procedures
 - b) Standard Occupational Procedures
 - c) Specific Occupational Procedures
 - d) Specific Operating Processes

5. **_____ Concept is followed while using a fire extinguisher.**
 - a) Fail
 - b) Pass
 - c) Near
 - d) Close

6. **_____ of equipment should be observed regularly.**
 - a) Change
 - b) Maintenance
 - c) Provision

d) Protection

Write Short Answers

1. What do you mean by hazards?
2. Define ergonomics.
3. What does SOP stand for?
4. Why Personal Protective Equipment is important?
5. What is meant by P.A.S.S?



Extended Response Questions

1. Analyse any two types of workplace hazards in detail.
2. Explain the procedure of using fire extinguisher.
3. Identify the importance of OHS at workplace.

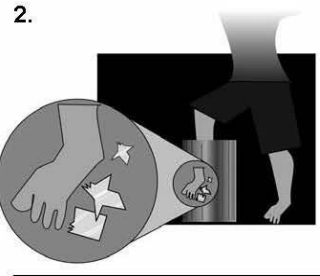

Constructed Response Questions

1. A person has been working as a domestic stitcher. Now he has moved to industry that works at a larger scale where he has to operate industrial sewing machine. Can you think of different safety precautions he should adopt while working at both workplaces? Give reasons.

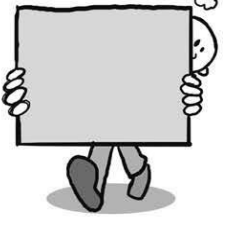
Activity: Write down in front of each Workplace hazard by describing Look-Think-Do procedure for each hazard.

WORKPLACE HAZARD/ ACCIDENT	LOOK! What is the Hazard?	THINK! Can the hazard Harm someone?	DO! Strategy to Remove the Hazard?
1. 			
2. 			
3. 			
4. 			

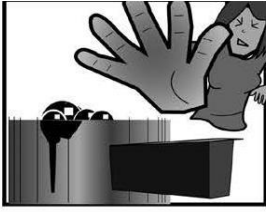
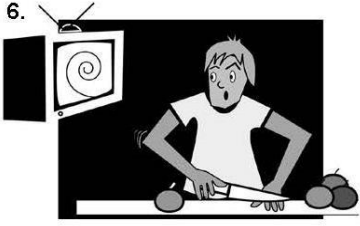
Activity: Write down in front of each Workplace hazard by describing Look-Think-Do procedure for each hazard.

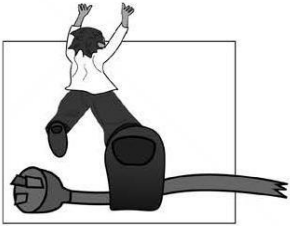
<p>5.</p> 			
<p>6.</p> 			
<p>7.</p> 			
<p>8.</p> 			
<p>9.</p> 			

INTRODUCTION TO FASHION DESIGNING



2

What kind of fashion do you like?

What is Silhouette?

How has clothing evolved over the years?

Students Learning Outcomes:

After studying this unit students must be able to: -

- define Fashion
- explain different categories of fashion (Garments, lifestyle, beauty sector)
- categories different tools and equipment used for fashion designing
- understand the importance of fashion in everyday life
- define the scope of Fashion designing on domestic level
- understand the importance of Fashion Designing in Local Market
- identify types of fashion (Haute Couture and Prêt-a- porter)
- explain the evolution of Fashion (mid 80's - till date)
- describe the development of Fashion Industry in Pakistan

Fashion is a form of self-expression and autonomy at a particular period and place and in a specific context, of clothing, footwear, lifestyle, accessories, makeup, hairstyle, and body posture. The term implies a look defined by the fashion industry as that which is trending.



Fashion is also a source of art, allowing people to display their unique tastes and styling.

Different designers are influenced by outside stimuli and reflect this inspiration

in their works. Fashion is unique, selffulfilling and may be a part of someone's identity.

Do You Know?

What is FASHION?

- Fashion is the accepted day to day way of dressing at a given time. If you see everyone wearing the same colour or style when they have not been the trend before, such is “in -fashion”.
- Never has and never will – Fashion is the total outlook of an individual of today and only for today. Though fashion evolves and some styles come back, it only apply for “now”. Even the retro fashion is never the same.

Field Visit:

- ❖ Visit library and an old book shop and consult magazines like Vogue, ELLE, and Bazaar.

Different Categories of Fashion

- Garments
- Lifestyle
- Beauty Sector

□ Garments

Different categories of garment are as follows:

1. Casual Wear
2. Formal Wear
3. Sports Wear

1. Casual Wear

Casual wear is informal dress code that is comfortable and relaxing to be worn. They mostly do not come with any kind of embellishment or any sort of adornments. It may include T-shirts, trousers, jeans and so on.

2. Formal Wear

Formal wear garments are mostly worn at special occasions. They tend to be highly embellished with luxury fabrics like silks, chiffons, satin, velvets, organza Gowns? You can take etc. They mostly include long flowy gowns with interesting cut lines. find out!

Point to Ponder!

3. Sports Wear

Sportswear is categorised as active wear worn during a sport or doing a physical exercise. The design of the garment depends upon the kind of sport you are doing. While designing sports wear it is important to keep in mind that it allows maximum comfort and flexible to body so you can do the sport with ease.

Interesting Information

Silhouette is what defines the outline of a garment. It refers to the overall shape that it creates when the garment hangs over the body. Silhouettes may vary from dress to dress depending on the style of the garment.

□ Lifestyle

Lifestyle is defined as a way or style of living. Lifestyle may be the interests, behaviors, work, activities and opinions of an individual, group or culture. Lifestyle is mostly adopted with



reference to the cultural and environmental context. In general the way a person dresses up, sets up his living spaces and his overall way of living defines his lifestyle.

Activity:

- ❖ Compare the rural and urban lifestyle of people living in Pakistan and collect reference pictures to support your assignment.

□ Beauty sector

Beauty sector involves self-adornment products like makeup, cosmetics related to skin, hair and other related accessories. Recent years have witnessed a rapid increase in peoples' inclination towards using such products for personal grooming. At the same time this sector has made a profound place in fashion industry.



1.2 Tools and equipment used for fashion designing

Tools and equipment are significantly important for a person who is supposed to produce a creative work. A fashion designer cannot work if he does not have his tools and equipment in hand. Enlist below are the important tools of fashion design without which design process cannot be carried out and executed.

1. Scissors:

It is an instrument used for cutting of fabric or paper etc. Scissors are of different types and used for different purposes:

Fabric Scissors: This kind of scissor is a bit heavy than a paper scissors. Scissors also have a long blade which is ideal for cutting fabrics; even for cutting several layers of material at the same time.

Paper Scissors: This kind of scissor is lighter in weight than fabric scissor. This scissor should strictly be used for cutting paper because changing the material for cutting can damage the blade.



Interesting Information

Pinking shears are scissors with zig zag instead of straight blades. They produce a zigzag pattern instead of a straight edge. They prevent fraying of fabric on raw hems by cutting fabric in a zigzag pattern. They are also useful when you need to reduce fabric bulk on seam allowances.

2. Tailor's Chalk:

Chalk is an essential tool for marking fabrics. It is mainly used to mark the measurements on fabric. The markings are not permanent can be easily removed or washed when not needed.



3. Tape Measure:

A Fashion Designer usually keeps a measuring tape with him during his work. This equipment is essential for fashion tools as it will allow creating a perfect measurements of the garments.



4. Dressmaker Pin Tools:

These fashion tools are a short straight, stiff piece of wire that is used for fastening pieces of fabrics or other materials together. The Dressmaker pin is helpful in joining the fabric pieces together before stitching as they allow fabric pieces to stay in place and make the process convenient to get completed.



5. An Adjustable Dressmaker Mannequins:

Using an adjustable mannequins will allow a fashion designer to make clothes without worrying about the sizes. They enable the designer to check and re check the measurements of the garment to get an accurately stitched product.–It will also be a great help for getting the correct positions of buttons, pockets, fasteners, hooks etc.



6. Calico

A white or off white cotton fabric used to make test garments. This is a very important step to make toils (test garments) before the final garment stitching as it will allow to identify and resolve any mistakes that can be corrected while stitching the garment on true fabric.



7. Sketch book and Trace Roll Paper:

The Sketch book and Trace Roll Paper are is a must-have fashion tool as it is used for creating sketches and detail work. Designers must have a skill for drawing; that is why design and tracing paper is crucial.



8. Sewing Machine:

The sewing machine is the one used for sewing fabrics and other materials. A sewing machine plays a vital role in the fashion design industry. It is the tool for making a variety of plain or patterned stitches.



9. Japanese Scale:

It is a scale used for measuring length and width of the fabric. It consists of smallest readings of 0.5 cm which help in accurate measurements.



10. French Curve:

A tool used in drafting a pattern manually and design to draw smooth curves. It is composed of several different curves used to create curves at different points of a garment.



2. Importance of fashion in everyday life

On a larger scale, fashion is important because it represents our history and helps to tell the story of the world. Clothes help to keep people ready for whatever they may face in life but fashion keeps up with the current crazes and changes that we all face so that we're ready for whatever life throws our way. Fashion design is the art of the application of design and aesthetics or natural beauty to clothing and accessories. Fashion design is influenced by cultural and social latitudes, and has varied over time and place. Fashion designers work in a number of ways in designing clothing and accessories.



2.1 Fashion in daily life:

Fashion is always considered the important part of our life. It has been followed from the ancient time but as time passed, the fashion trends changed. In the olden times, fashion was regarded as the possession for the high-class people but, as time and thinking of people have changed, the view about fashion also changed. In today's world fashion is accepted by people of all class and culture. Fashion is a word, which is recognized by all people of the society. Various culture and tradition has also



accepted fashion in its own way. People who want to be up to date with the latest fashion follow various fashion magazines and media. Fashion designers work hard to fulfill the wish of all people from various backgrounds. Therefore, fashion is very important in our life. Hence, many fashion designers work hard to create new designs, which can attract people and accept them.

2.2 Common Accessories in Fashion:

Fashion is incomplete without accessories. Various accessories such as designer belts, clutch, bags, jewelry, hair accessories etc. enhance your fashionable clothes. The latest fashion designers and stylists use various types of accessories to enhance and complement the design of the outfit in order to improve its look.

Interesting Information

A fashion accessory is a decorative item that supplements one's outfit. Items such as such as jeweler, gloves, handbags, hats, belts, scarves, watches, sunglasses, pins, stockings, bow ties, leggings, ties, suspenders, and tights.

2.3 Fashion Values and Beliefs:

Fashion values and beliefs totally differ according to the perspective about fashion. A true fashion designer values the beliefs of the people and designs clothes according to their taste. There are various values associated with fashion in different culture and designers need to incorporate them accordingly in their designs. Designers should also take care of the beliefs and cultural values of people associated with fashion too.

2.4 Fashion Online:

As this is an internet world, fashion can be easily located online. There are various websites, which offer fashion online and can be browsed as well as ordered from the comfort of the house. The latest trends can be followed through internet too. Online fashion gives you a broad view about not only national, but also international fashion trends.

3. Scope of Fashion designing on domestic level

Fashion designing is the science of geometry, color and drapery all rolled into one. It is associated with creating designs for menswear, women wear, teen fashion wear and extends to accessories like jewelry, and footwear also. Fashion designing is an intellectually satisfying and lucrative profession today.



As the domestic demand for ready to wear increase, the fashion industry today pivots on the evolving dynamism and energy of the international design world. Creative and innovative Fashion Designers rise to become Global Brand Icons, Media Personalities, Industry Stalwarts or ultimately, Celebrated Images symbolizing the remarkable look, feel and attributes to the era.



The fashion industry is a product of the modern age. Prior to the mid-19th century, virtually all clothing was handmade for individuals, either as home production or on order from dressmakers and tailors. By the beginning of the 20th century, with the rise of new technologies such as the sewing machine, the rise of global capitalism and the development of the factory system of production, and the proliferation of retail outlets such as department stores, clothing had increasingly come to be mass-produced in standard sizes and sold at fixed prices. Although the fashion industry developed first in Europe and America, today it is an international and highly globalized industry, with clothing often designed in one country, manufactured in another, and sold in a third.

- **Fashion Designing as a field of study:** Fashion Designing is one of the upcoming career options in today's world and it is becoming famous day by day among the people with creative minds. It is glamorous, appealing, and exciting career option. With this degree students have number of choices in front of them. The fashion designers have varied options including designing, research, cloth production, textile designing, etc.

Interesting information

In Pakistan People studying fashion can adopt following career paths:

- Consultant
- Stylist
- Costume designer
- Illustrator.
- Fashion designer
- Visual merchandiser
- Merchandiser
- Costume stylist
- Personal stylist
- Fashion Blogger
- Retail buyer
- Personal shopper
- Fashion publicist (PR)
- Fashion curator

- **Who Is a Fashion Designer?** A fashion designer is a person who studies fashion trends, sketches designs, picks fabrics and oversees the general production of clothing and accessories. Most people often mistaken tailoring/dress making to fashion designing, although they work hand in hand, there is a significant difference between them.
- **Skills Required to Become a Fashion Designer**
 - ✓ Creative Skills
 - ✓ Good eye for materials
 - ✓ Business skills
 - ✓ Strong visualization skills
 - ✓ Information about current fashion trends
 - ✓ Drawing and sketching skills
 - ✓ Soft skills
- **Product promoters:** There are many other options as well for instance you can also work with Film production units as TV/Film fashion program producers/costume designers etc.

Activity:

- ❖ Invite guest speaker from garment industry to address the students to highlight scope and importance of Fashion

□ What Is Pret-A-Porter Exactly?

Pret-a-Porter fashion, also known as ready-to-wear fashion, describes the ready-made, ie not tailor-made, fashion collections of designers and labels. Ready-made fashion is one that we find in retail in various, fixed



sizes on the shelves. the designer’s Pret-a-Porter collections are admired and celebrated. For the designers themselves, the Pret-a-Porter collections are extremely important in addition to haute couture, because the ready-to-wear fashion boosts the marketing of designers enormously

Interesting Information

Capsule collection is a composition of different pieces of garment that can be inter-changeable and complement each other while wearing In different ways. Capsule collection cannot go out of fashion as it consists of basic fashion elements such as shirts, skirts, trousers, jackets etc.

3.2Haute Couture:

Haute couture is defined as the high end or luxurious fashion that majorly fulfills the demands of “high society” of fashion collections by designers. The



term comes from France, Haute means high end and couture means fashion and refers to the upscale designs of fashion designers from the top tier. The French fashion association sets rules and specifications so that the ranks of Couturiers remain exclusive

Do You Know?

International designers that are working for brands like Chanel, Dior or Ellie Saab are termed as haute couture designers or simply couturiers.

4. Evolution of Fashion

4.1 Know the evolution of Fashion (mid 80’s – till date)

Fashion is a universal subject, a language understood and spoken by many. When we look back over the last 100 years, the change and influence fashion has seen has been exponential. Decade after decade, new trends have been introduced, themselves heavily influenced by pop culture,

political attitudes and inspiring style icons of the time. It is a mode of expression for so many and considered a necessity by others. To be 'fashionable' was very much associated with wealth in bygone years but as we entered into the glittering Great Gatsby era of the 1920s, fashion became liberated as Coco



Chanel took to the throne (in a fashion sense, of course.) She popularized so many pivotal fashion trends that we still wear today including the little black dress, espadrilles and costume jewelry but she was also a driving force behind this liberation movement, an advocate for casual dressing as corsets were removed and trousers for women became the new wardrobe staple.

By the 1950s, the French designer, Christian Dior, had introduced us to one of fashion's most widely-worn trends – the pencil skirt. A popular choice for the First Lady of the time, Jackie Kennedy. In what became known as the 'rebellious era', the 1960s was a great contrast to previous decades. It was a time of great upheaval, both politically and creatively and is synonymous with a much shorter hemline as governed by British designer, Mary Quant presented and



her mini skirt. Mod fashion also came into play, with bold geometric shapes, bright primary colours and psychedelic prints introduced by designer, Emilio Pucci. It was the decade of experimentation and non-conformity, which carried on through to the 1970s. As hemlines began to get longer and trousers



©WorthEncyclopedia.com

grew tighter, bohemian dressing took center stage – literally, in the case of style icon, Joni Mitchell. Long, flowing skirts, the DVF wrap dress and embroidered, peasant style clothing became increasingly popular, advocated by stores including Biba and Laura Ashley. The



1970s is a perfect example of the cyclicity in fashion trends. Last summer, more than 40 years on, we have seen the off-shoulder Bardot and embroidery trends taking over our favorite high street stores once more in a revival of the most popular looks from the decade.



Today, the fashion industry is a highly reputable, competitive and wonderfully influential business. Our searing dedication and interest in the biannual shows at fashion week or excitement following the arrival of new season stock in Topshop has not wavered. Our commitment to fashion and looking stylish still remains original and passionate, more than 100 years on.

Activity:

- ❖ Visit any cultural museum to observe the evolution of Fashion Designing

5. Understand the development of Fashion Industry in Pakistan

Pakistan is the world's 4th largest producer and 3rd largest consumer of cotton. Because of its plentiful, indigenous cotton supply, the textile industry is central to the Pakistani economy and is both a source of employment and a source of exports.



Pakistan's industrialization began in the 1950s with the textile industry at its center. The Textile and Clothing Industry has been the main driver of the economy for the last 50 years in terms of foreign currency earnings and jobs creation. The Textile and Clothing Industry will continue to be an important



engine for future growth of the economy; there is no alternative industry or service sector that has the potential to benefit the economy with foreign currency earnings and new job creation. Pakistani fashion industry has great potential which can earn huge foreign exchange through export of fashion industry products if it succeeds to catch the attention of western buyers.

These views were expressed by the head of Italian delegation Ms Stella Maria Novarino, Ms Diana Battaggia and UNIDO representatives speaking at a moot here at the Lahore Chamber of Commerce and Industry (LCCI). They said the world was going to other regional countries to buy handmade embroidery and products for fashion industry despite the fact that Pakistan has far better expertise. Members of Italian UNIDO delegation Ms Danielle Doujour, Ms Elisabetta Latanzio Illy, Federico Barassi, Dino Fortunato also spoke on the occasion. LCCI Senior Vice President Khawaja Shahzad Nasir, Vice President Faheem-ur-Rehman Saigal, Convener LCCI Standing Committee on Women Business Development AasiaSaail Khan represented the business community besides veteran businessman Rehmatullah Javeed.

Ms Stella Maria Novarino said that all those women are not just workers but artists who are doing embroidery, stitching and other related works. “We also want to change the perception of Pakistan in the world through Pakistani finest quality work and art and want to highlight the talent of Pakistani women that is fit for international fashion



Industry”, She added. She said that Pakistani women entrepreneurs have everything that Italian Fashion Company needs. There is no reason not to work with them. Faheem-ur-Rehman Saigal said that fashion industry of Pakistan can get a good share from the international fashion market worth billions of dollars. He said that from 220 million population of Pakistan, women comprise of more than 50 percent of it. Through introducing new projects, a large number of populations can be benefitted and contribute in national economy. He said that Pakistan’s Fashion designing and clothing industry has become an important dimension for national economy because of its

export potential. He said that decision makers should realise its significance in view of its huge potential for future expansion and give all possible facilities.

Field Visit:

brief report.

- ❖ Visit garment industry to learn the process flow and make a

Web Links

- ✚ <https://www.britannica.com/art/fashion-industry>
- ✚ <https://medium.com/@catherinewatts/10-fashion-tools-every-aspiring-designer-needs-to-succeed-9027366bd37b>
- ✚ <https://sewguide.com/pret-a-porter/>
- ✚ <https://sewguide.com/evolution-of-history-of-fashion/>

EXERCISE**Tick (✓) the suitable option**

1. **The type of garments worn at special occasion**
 - a) Casual wears
 - b) Formal wears
 - c) Sportswear
 - d) Active wears

2. _____ **is luxury fabrics**
 - a) Silk
 - b) Cotton
 - c) Lawn
 - d) net

3. **The type of scissors having zig zag blade known as**
 - a) Fabric scissor
 - b) Paper scissors
 - c) Pinking shears
 - d) shears

4. **To mark the measurements use**
 - a) Measuring tape
 - b) Chalk
 - c) Pins
 - d) scissor

5. **The smallest reading of Japanese scale starts from**
 - a) 0.5
 - b) 0.05 cm
 - c) 0.5m
 - d) 0.05

6. A tool used in drafting/ pattern making to make smooth curves known as
- Japanese scale
 - French curve
 - Tracing wheel
 - Tracing paper
7. Fashion design is influenced by
- Environment
 - Culture
 - Social latitudes
8. The proliferation of retail outlets and stores had increasingly come to be mass produced in which era
- Beginning of 20th century
 - Mid of 20th century
 - Beginning of 21th century
 - Mid of 20th century
9. Pret a porter means
- Ready to wear
 - Ready to sew
 - Ready to print
 - Ready to sale**
10. Which category of fashion boosts the marketing of designers
- Haute couture
 - Pret a porter
 - Luxury pret
 - Formal wears

Write Short Answers

- How haute couture is expensive/ luxury fashion?
- Define capsule collection?
- Who introduced pencil skirt, briefly describe the history in context with rebellious era?

4. Write down a short note on prints/ designs introduced by Emilio Pucci with reference of Mod Fashion
5. Define fashion designing in your own words.
6. Write a short note on textile industry of fashion and its importance?
7. What are the main skills required to become a fashion designer?
8. How Pakistan's fashion industry has become an important dimension for national economy?
9. Write a short note on fashion values and beliefs?
10. What are silhouettes, describe how these are important in fashion?

Constructed response question

1. Scroll the magazines and books; collect the information about Victorian era and Mod fashion. Compare the terms with the help of text and visual references
2. Choose any one national and an international fashion designer and find the similarities and differences in their works.

Project:

- Make a timeline/ journal/ book, manually by putting information about famous eras from mid-80s to mid-20s.
- Write the gathered information in points and describe with pictorial evidence.
- Decorate the journal that should be visually appealing by creating backgrounds etc.

DRAWING-I

3

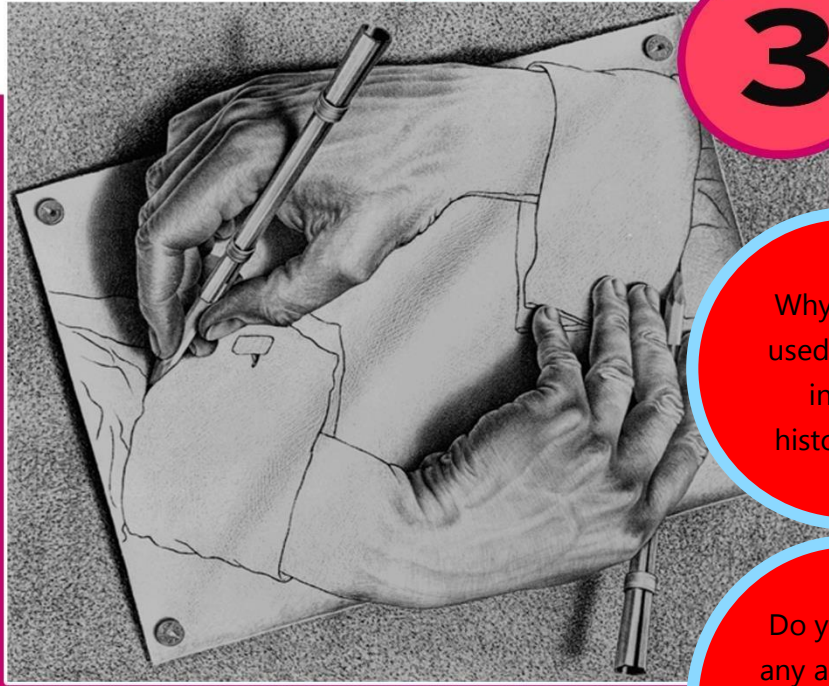

Why people used to draw in pre-historic era?

Do you know any alternative way to express thoughts other than talking?

Students Learning Outcomes:

After studying this unit students must be able to:

- define the basics of drawing
- explain the concept of still life
- explain line proportions of objects
- understand Perspective of object
- apply Shading techniques
- enlist different drawing tools (Drawing Pencils, eraser, blenders, charcoal sticks and pencils)
- define the concepts of Nature drawing
- understand the details of studying nature drawing
- apply Shading techniques using different media

Is there any other medium other than pencil?

Sometimes when you see things and want to draw them but unable to capture the real form, how would you resolve it. Drawing is the solution for it.

“Drawing is all about how you perceive the world around you and interpret it into your own words.”

Basics of Drawing

It is impossible to make a drawing unless the artist has a clear understanding of the type of drawing that is to be created, and the visual language that is to be used which will give form and expressive dynamics. If you organise the lines, you can make shapes; and when you carry a bit further and add dark and light shading, your drawings begin to take on a three-dimensional form and look more realistic.

Do You Know?

Drawing is one of the oldest forms of human expressions

Tools and Equipment used for Drawing

One of the great things about drawing is that you can do it anywhere, and the materials are very inexpensive. Following are the tools and equipment which are used for drawing:

1. Sketch Book/Sketch Pad

Sketch Pads are available in a wide variety of sizes, textures, weights, and bindings. They are particularly handy for making quick sketches and when drawing outdoors. Smooth- to medium grain paper texture is often an ideal choice.



2. Pencil

Pencils are available in three basic families HB, B and H. The softer B Pencils are generally considered the best for shading. The HB and H are good choices for fine, light, even shading. Pencil grades from HB through H, 2H to 5H get progressively harder and are easier to keep sharp.

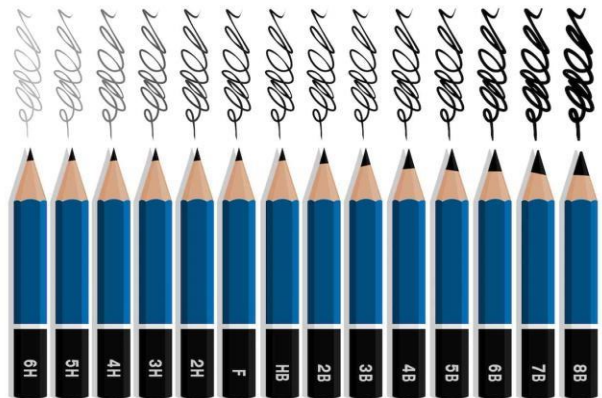

3. Charcoal

Charcoal is available in two forms: Charcoal stick and Charcoal pencil. These are essentially charred wood and are one of the oldest drawing materials. These are made of carbonized wood, the sticks are graded as soft or hard and available in four thicknesses: thin, medium, thick, and extra thick sticks. Thin sticks work well for fur, feathers, and other fine detail, while charcoal pencil works well for large areas and minor details.



4. Sharpening Tools

Sharpeners are available in variety of forms. These are used to sharp wooden-barreled pencils, charcoal pencils, etc. They allow you to sharpen the point of your medium to suit the type of work you are doing.



5. Erasers

Erasers are useful for rubbing out mistakes or for blending. Harder plastic or vinyl erasers pick up less pigment and stay cleaner. They can be used on their edge to make crisp, incised lines in areas of deep tone; alternatively, use the



sharp corners to make patterns and describe texture. They also remove stubborn pencil or graphite marks and small errors.

Interesting Information

A kneaded eraser is an integral part of drawing. It can be formed into small wedges and points to remove marks in very tiny areas. Vinyl erasers are good for larger areas, they remove pencil marks completely.

Concept of Still Life

Still life drawings offer a great opportunity to learn and practice a variety of drawing skills, including developing form, applying shading, and using perspective. Still life compositions traditionally depict a carefully arranged grouping of a number of household objects, such as fruit, vegetables, glassware, or pottery, all of which offer a wide range of textures,



sizes, and shapes. But you do not have to restrict yourself to traditional items, use your artistic skills to get as creative as you want.

Do You Know?

You can practice your skills of drawing through proportions by using different objects such as shoe, glass, bottle, jug, stool, chair, vase, etc.

Line Proportion and Perspective of Object in Still Life

Creating a good still life composition is simply arranging the elements of a drawing in such a way that they make an eye pleasing and harmonious scene. It makes easy to draw by following a few guidelines:

1. Choosing a format that fits the subject.
2. Establishing a center of interest and a line of direction that carries the viewer's eye into and around the picture
3. Creating a sense of depth by overlapping objects, varying the values, and placing elements on different planes.

Interesting Information

Composing still life is a great experience because you select the lighting, you place the elements where you like, and the objects do not move. Test out the arrangements in small, quick thumbnails, like the ones shown below. These studies are invaluable for working out the best possible composition.

Activity-3.1: Draw Still Life

Step One : From your thumbnail sketches, choose a horizontal format. Notice that the tureen is set off-center, if the focal point were dead center, your eye would not be led around the whole drawing, which would make a boring composition. Then lightly block in the basic shapes with mostly loose, circular strokes, using your whole arm to keep the lines free.

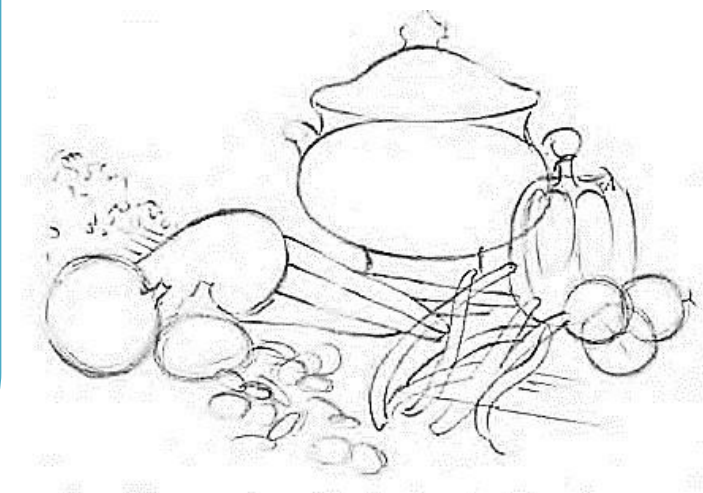

Step Two: Next refine the shapes of the various elements, still keeping your lines fairly light to avoid creating harsh edges. Then, using the side of an HB pencil, begin indicating the cast shadows, as well as some of the details on the tureen.

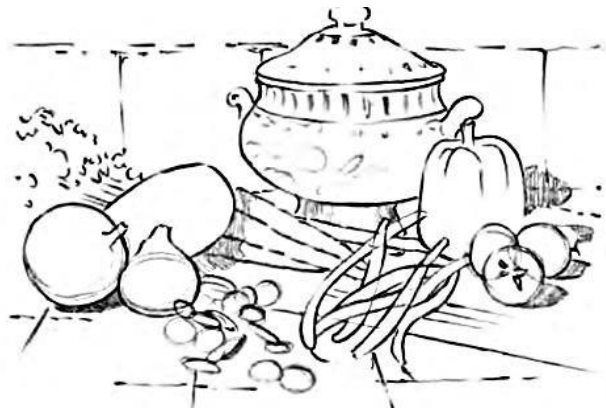

Step Three: Continue adding details on the tureen and darkening the cast shadows. Then start shading some of the objects to develop their forms. You might want to begin with the bell pepper and the potato, using the point and side of an HB pencil.



Step four: Build the forms of the other vegetables, using a range of values and shading techniques. To indicate the paper skins of the onion and the garlic, make strokes that curve with their shapes. For the rough texture of the potato, use more random strokes.



Step five: When you are finished developing the light, middle, and dark values, use a 2B pencil for the darkest areas in the cast shadows (the areas closest to the objects casting the shadows).



Perspective of Object:

Drawing is actually quite simple, just sketch the shapes and masses you observe. Sketch freely. If you discover something wrong with the shapes, you can refer to the rules of perspective below to make corrections. Your drawings do not need to be tight and precise as far as geometric perspective goes, but they should be within the boundaries of these rules for a realistic portrayal of the subject. You need to learn different types of perspectives which are given below:

One Point Perspective: In one point perspective, all the lines that are not vertical or horizontal vanish into one point in the image. This point is often located in the middle of the picture but it can be anywhere.

Two Point Perspective: In two point perspective, all non-vertical lines vanish into two points of the same height at the border of the image.



*Let's See, If you can identify
ONE POINT & TWO POINT
perspective.....*

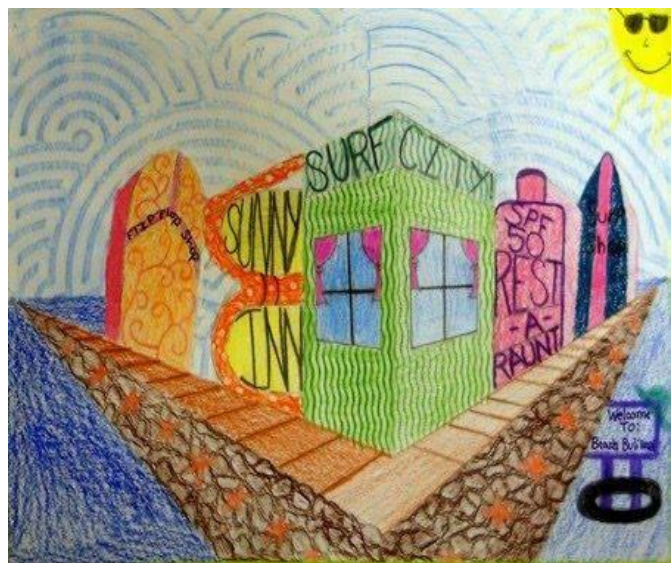

Interesting Information

The Points in which the horizontal & vertical lines merge are called vanishing points.

Shading Techniques

There are many ways to shade with pencils. The four main techniques generally used are shading, hatching, cross-hatching and following the form. Each one is demonstrated below.

- 1. Shading:** Shading with a pencil when marks are very close together so that they form a continuous tone on paper.

Do You Know?

You can practice shading by arranging various things such as jewellery box, pencil box, book shelf, etc.

- 2. Hatching:** Hatching with a pencil when have a gap between each mark and arrange them in a way to create continuous coverage.
- 3. Cross-hatching:** Cross-hatching with a pencil when pencils are crisscrossing lines to create coverage. Try experimenting with different coverage techniques.

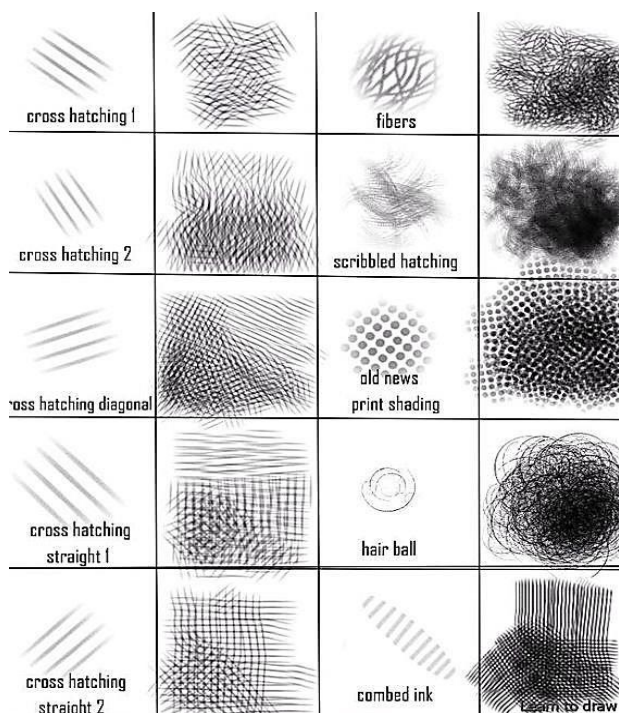
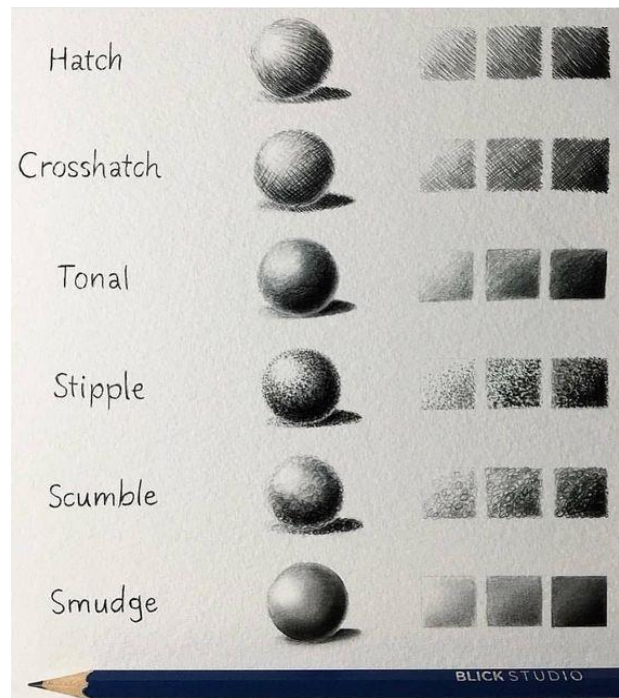

Let's put into practice your learnt material

Activity: 3.2
Making a Form



1. Study your subject closely, and lightly sketch the simple shapes. For example, that the pear is made up of two circles, one large and one small.

2. Begin shading with strokes once the basic shapes are drawn

3. That are consistent with the subjects' rounded forms, as shown in the final drawings.

Nature Drawing

Nature drawing is recording a scene/situation that is moving and lifelike. Think animals/birds/trees always in motion and must be sketched quickly. Nature is everything that is not man-made and it encompasses the universe. Framed landscape-type pictures always look enchanting on any wall. When you study the landscape outdoors, remember that you will never see a true straight line, it is only man who makes things through mathematical perspective. Many beginners believe that flowers are too difficult to draw and therefore they feel hesitant to draw. However, a flower can be developed step by step from its most basic shapes.

Activity: 3.3
Practicing with
Flowers

Step 1: Draw Guidelines. Use HB pencil to block the overall shapes of rose and petal by using a series of angular lines. Make all guidelines light so you would not have trouble removing or covering them later.

Step 2: Continue adding guidelines for the flower's interior by following the angles of the petal edges.

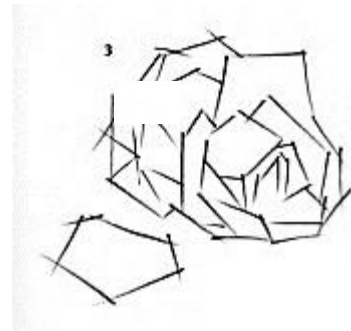
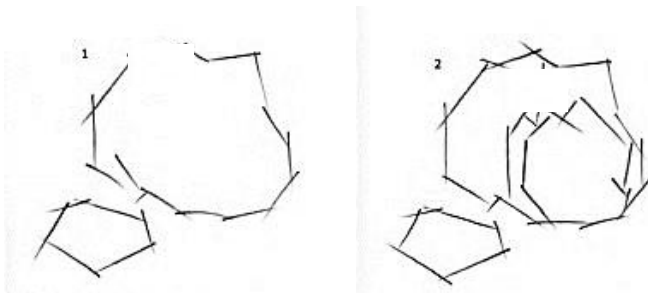

Step 3: Add values and begin shading. Stroke from inside each petal toward its outer edge.



Step 4: Develop Shades from the outer edge of each petal, meeting the strokes you drew in the opposite direction. Use what is known as a stroke and lift technique.



Step 5: For this technique, you should draw lines that gently fade at the end. Just press firmly, lifting the pencil as the stroke comes to an end.

Do You Know?

You can practice nature study through various natural elements such as: Leaves, Branches, Trees, Roots, etc.

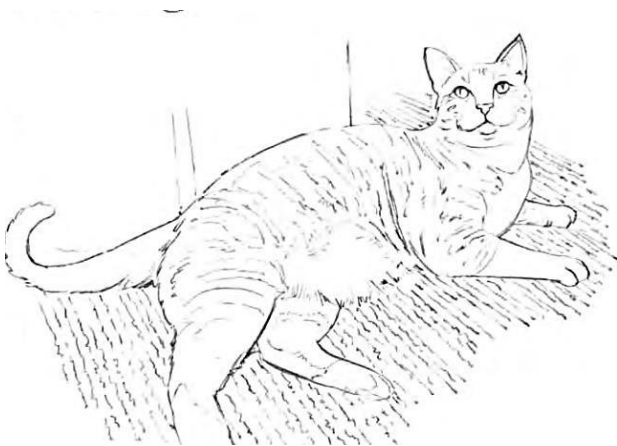

Step 1: Draw a smaller oval over the cat's stomach, blocking in the bulging fur of its underbelly. Then create the full outline of the cat's body, adding its four legs. Next draw the triangular ears and place the eyes, nose, and mouth.

Step 2: Erase any guidelines you no longer need, and map out the basic tabby pattern of the cat's coat. Use curving lines to suggest the cat's rounded form. Then scribble in the contrasting parallel lines of the carpet.

Step 3: Next apply shading to the cat's striped coat. Go over the graphite with a blending of shades to allow soft gradations, which best illustrate the cat's fluffy fur. You can also use the stump to soften edges, such as along the delicate fur of the cat's underbelly.

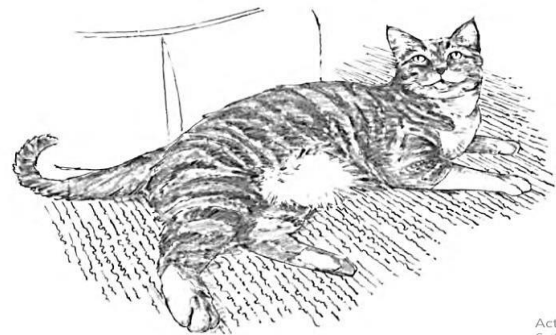
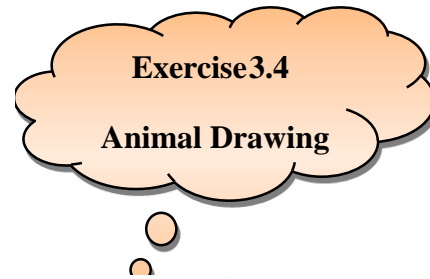

Step 4: Now continue to build up the cat's darker values, developing the dark stripes of the cat by applying heavier strokes in the same direction as the fur growth. For the ridged carpet pattern, lightly smudge shading in every other stripe using graphite dust and a blending stump.

Exercise 3.5

Landscape

Step One To begin this scene, place the basic shapes, refine them, and then add values. Apply light and middle values to establish a backdrop for more intense shading.

Step Two Refine the shapes of the trees and the road. Then use light vertical strokes for the trees in the background. Continue adding details as you work toward the foreground.

Step Three: Continue adding values, and work your way to the foreground.

Step Four : Use the side of HB pencil for the wide strokes of foliage and shaded areas.

Step Five: Add final dark values. Continue the foliage texture, leaving some areas lighter to create depth. Lightly shade the sky areas; then clean out the cloud forms with a kneaded eraser,

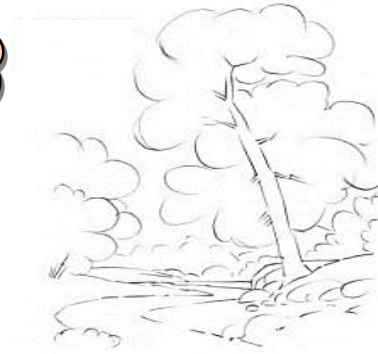

Key Points

Drawing is amazingly versatile, it can range from simple, unshaded contour line drawings to complex, fully rendered compositions with a complete range of tonal values.

Sketch books are of various types which help in drawing such as grained sketchbooks, plain paper sketchbook, watercolor sketchbooks

Pencil grades from HB through H, 2H to 5H get progressively harder and are easier to keep sharp.

Charcoal can be used in both raw form and pencil form in order to make a drawing

Still life composition should never be centralised. A quick rough grid can be made to ensure it

Web Links

<https://unsplash.com/s/photos/shading-techniques-in-drawing>

<https://www.diys.com/basic-drawing-techniques/>

<https://www.craftsy.com/post/sketch-techniques/#>

Exercises**Tick (√) the suitable option:**

- 1. Just like writing or speech, drawing is a form of**
 - a) Dynamics
 - b) Communication
 - c) Contouring
 - d) Improvising
- 2. Drawing can be done with**
 - a) Knife
 - b) Pencil
 - c) Cafeteria
 - d) Anywhere
- 3. The ideal choice for sketch file is**
 - a) Plain Paper
 - b) Smooth to medium grains
 - c) Extremely Grainy
 - d) Porous
- 4. Best pencils to use for shading in a drawing is**
 - a) B Pencils
 - b) H Pencils
 - c) HB Pencils
 - d) 5H Pencil
- 5. Shading in any drawing adds**
 - a) Focal Point
 - b) Values and Depth
 - c) Colour
 - d) Crudeness

Constructed Response Question

You have been given a task to identify and draw a Landscape out of below given images. You need to keep in mind the horizon line before drawing the Landscape. Give reasons why horizon line creates a beauty in Landscapes.



Short Answers

1. What are the basic tools used for drawing?
2. Is pencil the only thing through which we can draw?
3. What are the things to keep in mind while arranging a still life?
4. What is the difference between Still life and Nature drawing?

Extended Response Question

1. What is the definition of perspective and explain different types of perspectives with examples?
2. Write down the importance of Drawing.

Project:

- ❖ Make a still life drawing and shade it with the help of three shading techniques.

Medium: Pencil or Charcoal

BASICS OF DESIGN



4

Why it is important to study color Theory ?

What are the basics of Design?

How colors are used in design?

Students Learning Outcomes:

After studying this unit students must be able to:

- ✓ define the importance of Colour Theory in drawing and Design
- ✓ identify the difference between Primary, Secondary and Tertiary Colours
- ✓ understand different Colour Schemes/Combinations
- ✓ understand the characteristics of Colours (Hue, Value and Chroma)
- ✓ apply different colour terms for developing designs
- ✓ Define the Elements of Design
 - line
 - shape
 - form
 - colour
 - texture
 - space
- ✓ recognise the Principles of Design
 - balance
 - rhythm
 - emphasis
 - composition
 - proportion
 - repetition
- ✓ understand different types of design:
 - geometrical
 - floral
 - abstract
- ✓ apply basic media and materials (Pencil colours and poster paints)

Design plays an important part in almost every element of our lives. Design can be observed in fashion, interiors, products, video games, software interfaces, branding, animation, publishing, advertising, and many more areas. We can express feelings and ideas through designs.

Colour Theory

Color theory is a set of rules that combines creativity and science. Color theory sets the fundamental guidelines around color combinations and harmony. Designers and artists rely on color theory to make the correct choices for their projects but they are not the only ones who use it. Most people unknowingly make everyday decisions based on color theory and color harmony. Understanding the guidelines of color theory can help you in so many areas of life, from your business to your clothes.

Importance of Colour Theory in drawing and Design

We live in a highly visual world and it is impossible to master the art of visual communication without a good grasp of color theory. The colors in your design need to be purposeful and have meaning in their use. Color is helpful in communicating your message because it draws attention, sets the tone of the message, and guides the eye where it needs to go. It presents a sense of direction and recognition that people can identify and relate to.



Colours are everywhere. In our daily lives, we are constantly surrounded by colours.

These colours can influence our emotions i.e. how we feel about

someone. Marketers have been using the psychology of colors for decades and often draw on them to gain an emotional response from the customer.

Guiding Questions

- What is color?
- How do we represent and create color?

Interesting Information

Your eye can see different colors because a part of your eye called the retina is sensitive to different wavelengths of light.



Interesting Information

The first color wheel was presented by Sir Isaac Newton in the 17th century when he first discovered the visible spectrum of light.

Do You Know?

Color theory is a body of practical guidance to color mixing and the visual impacts of specific color combinations.

COLOUR THEORY

The Artist - 2020

Primary Colours
3 pigment colours that can not be mixed or formed by any combination of other colours. All other colours are derived from these 3 hues.

Secondary Colours
These are the colours formed by mixing two primary colours.

Tertiary Colours
These are the colours formed by mixing a primary and a secondary colour. That's why the colour is a two-worded name, such as blue-green, red-violet, and yellow-orange.

Analogous
Analogous colours sit next to one another on the colour wheel. These colours are in harmony with one another.

White, black and gray are considered to be neutral.

Value
Value refers to the relative lightness or darkness of a certain area.

Tint
A tint describes a colour that is mixed with white.

Tone
A tone describes a colour that is mixed with grey.

Shade
A shade describes a colour that is mixed with black.

Monochromatic
The term monochrome refers to the use of one colour or various shades and tints of one colour in a single form.

The generic meaning of colour
(Western Culture)

- RED:** Passion, Love, Fire, Anger, Blood
- ORANGE:** Energy, Happiness, Vitality, Stimulation
- YELLOW:** Sunshine, Happiness, Hope, Deceit
- GREEN:** New Beginnings, Abundance, Nature
- BLUE:** Sky, Calm, Responsible, Sadness, Sea
- VIOLET:** Creativity, Royalty, Wealth, Ambition
- BLACK:** Mystery, Elegance, Evil, Death, Power
- GRAY:** Moody, Conservative, Formality
- WHITE:** Purity, Cleanliness, Virtue, Innocence
- BROWN:** Nature, Wholesomeness, Dependability
- TAN OR BEIGE:** Conservative, Piety, Dull
- CREAM OR Ivory:** Calm, Elegant, Purity

Warm Colours
They are vivid and energetic, they are visually and emotionally exciting. They remind us of fire and heat.

Cold Colours
They give an impression of calm, and create a soothing impression. They remind us of cold water.

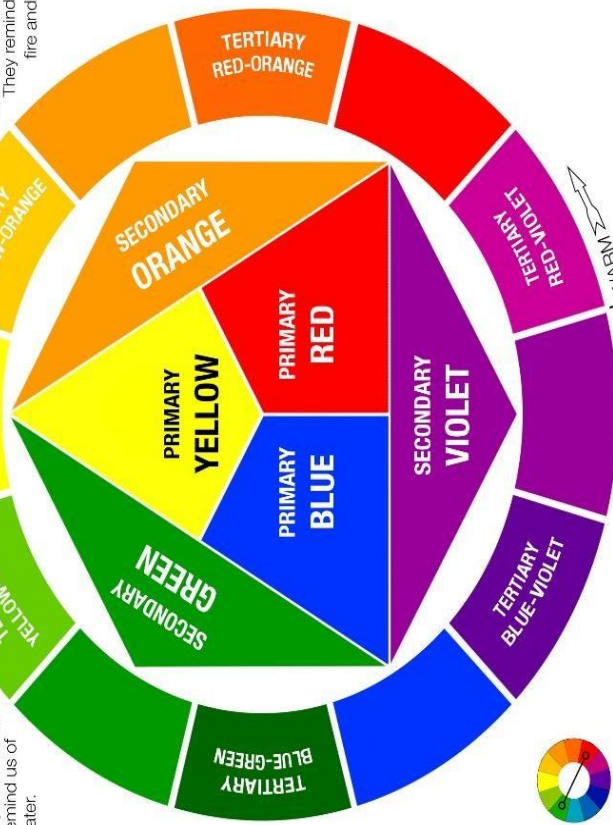

Complementary Colours
Colours that are opposite each other on the colour wheel are considered to be complementary colours (example: red and green).
When put together, they appear more vivid than when apart.

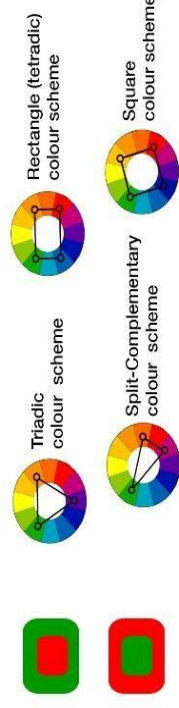

1.1 Colour:

Colour is light, and light is composed of many colors. The ones that we see are the colors of the visual spectrum i.e. red, orange, yellow, green, blue and violet. Objects absorb certain wavelengths of light and reflect others back to the viewer. We perceive these wavelengths as color.

1.2 Colour Wheel:

Color wheel is the abstract illustrative organization of color hues around a circle that shows relationship between primary, secondary and tertiary colors. On the color wheel red, yellow and blue primary colors are arranged at three equally spaced points and secondary and tertiary colors are arranged between them.

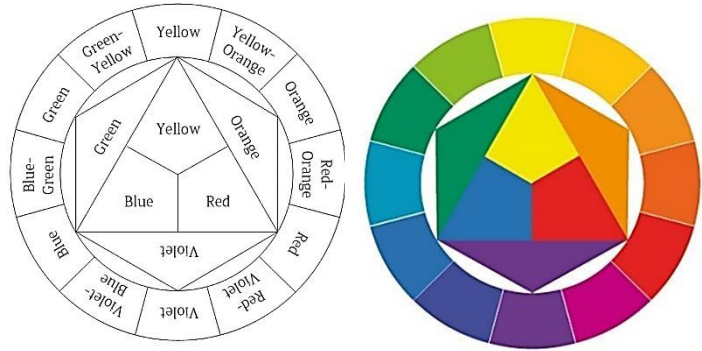

1.2.1 Difference between Primary, Secondary and Tertiary Colours

★ Primary Colors:

Primary colors are not mixed from other elements and they generate all other colors.

- ✓ Red
- ✓ Yellow
- ✓ Blue

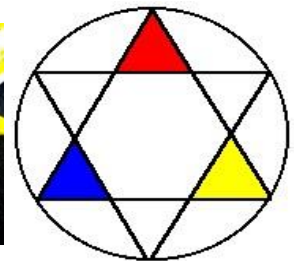

Point to Ponder!

Keep in mind that the color mixtures above only work if you use the purest form of each primary color. This pure form is known as a color's hue, and you'll see how these hues compare to the variants underneath each color in the color wheel

Activity:

Think of primary colors as your parent colors, anchoring your design in a general color scheme. Any one or combination of these colors can give your brand guardrails when you move to explore other shades, tones, and tints. When designing or even painting with primary colors, don't feel restricted to just the three primary colors listed above. Orange isn't a primary color, for example, but brands can certainly use orange as their dominant color. Knowing which primary colors create orange is your ticket to identifying colors that might go well with orange -- given the right shade, tone, or tint. This brings us to our next type of color .

*** Secondary Colours:**

Secondary colors are the colors that are formed by combining any two of the three primary colors listed above. Check out the color theory model above -- see how each secondary color is supported by two of the three primary colors? By mixing two primary colors, a secondary color is created.

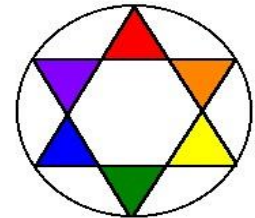
*** Tertiary/Intermediate Colours:**

Tertiary colors are created when a primary color mixes with a secondary color that comes next to it on the color wheel. There are six tertiary colors that are given below:



- ✓ Red + Purple = Red-Purple (magenta)
- ✓ Red + Orange = Red-Orange (vermillion)
- ✓ Blue + Purple = Blue-Purple (violet)
- ✓ Blue + Green = Blue-Green (teal)
- ✓ Yellow + Orange = Yellow-Orange (amber)
- ✓ Yellow + Green = Yellow-Green (chartreuse)

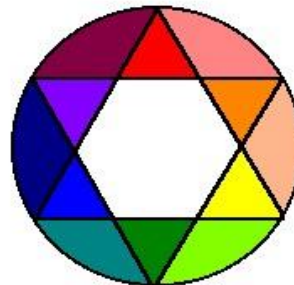

Interesting Information

The most important component of tertiary colors is that not every primary color can match with a secondary color to create a tertiary color. For example, red can't mix in harmony with green, and blue can't mix in harmony with orange -- both mixtures would result in a slightly brown color



1.3 Temperature of Colour:

Colour temperature is the warmness or coolness of a colour.

1.3.1 Warm colours:

Warm colors are associated with the fire, heat, sun and warmer temperature. They tend to advance in space and can be overwhelming for example, Red, orange or yellow.

Warm colors make objects look closer in a painting or drawing.

Interesting Information

- Warm colors are found on the right side of the color wheel
- Cool colors are found on the left side of the color wheel.



This is an illustration of the use of Warm colours.



1.3. 2 Cool Colors:

Colors which are associated with shadows are cool colors. They are the colors found in snow and ice and tend to recede in a composition, so they are good to use as backgrounds. Note the **cool** color scheme in this painting (greens, purples and blues)



This is an illustration of the use of cool colours

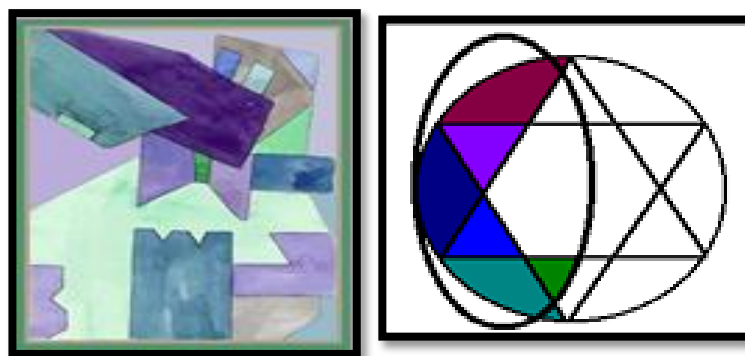

Activity:

1. Create a color wheel identifying primary, secondary, and tertiary/intermediate, Warm and cool colours
2. Create or show use of tints, tones and shades.

Material required

- Pencil
- Eraser
- Sharpener
- Poster colors
- Compass

Procedure

- Make a circle and divide it into 12 parts.
- Fill the top wedge with red color that is a primary color and can't be obtained by mixing any other color.
- Now fill 2 other bottom wedges with yellow and blue color that are also primary colors following the triangle path for each color.
- Moving clockwise, skip over the circle next to red. Find the triangle pattern associated with this circle. You'll now be adding secondary colors in the spaces midway between each two primary colors.
- Moving clockwise, fill the circles with orange, green, and purple.
- If using paint, mix an equal amount of primary color into the one next to it, around the outside of the original three colors.
- Moving clockwise from red, find the triangle pattern for the next three colors. This time you'll be adding the tertiary colors.
- Fill the circles clockwise from red with red, green, Orange, yellow and blue purple.
- If using paint, mix a secondary color with an equal amount of the color next to it on the wheel.
- Moving clockwise from orange, find the final triangle pattern for the last 3 colors.
- Fill in the circles clockwise with orange yellow, green, blue, and Purple, red.

Instructions:

- ✓ Don't waste paint. If you spill clean it up immediately.
- ✓ Work on this assignment in class, you will not be allowed to turn this in late.
- ✓ Use only black pen to label the colours.

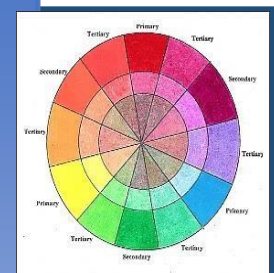

Do You Know?

Yellow and blue, they create a playful and authoritative look

1.4 Colour Schemes/Combinations:

A color scheme is the choice of colors used in design for a range of media. Color schemes are used to create style and appeal. Colors that create an aesthetic feeling when used together will commonly accompany each other in color schemes

Interesting Information

- Complementary colours are found exactly opposite to each other on a colour wheel.

1.4.1 Complementary colours

The colors that are positioned opposite one another in colour wheel are complementary colors. A combination of this caliber provides a high impact and a high contrast color combination. When put together, these colors more prominent and brighter.

This painting has complementary colors and their values



Red & Green

Blue & Orange

Purple & Yellow

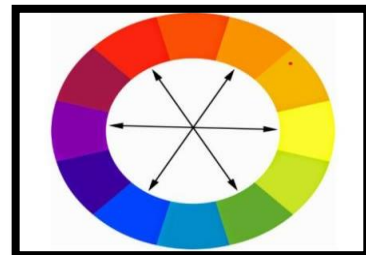

1.4.2 Split Complementary:

The split-complementary color scheme is a variation of the complementary color scheme. In addition to the base color, it uses the two colors adjacent to its complement. This color scheme has the same strong visual contrast as the complementary color scheme, but has less tension

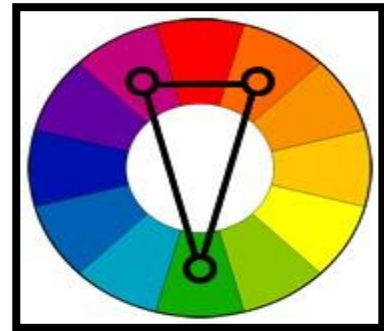

1.4.3 Double Complementary

Double-complementary scheme is a combination of two complementary color pairs. This is the richest color scheme, which contains four colors.

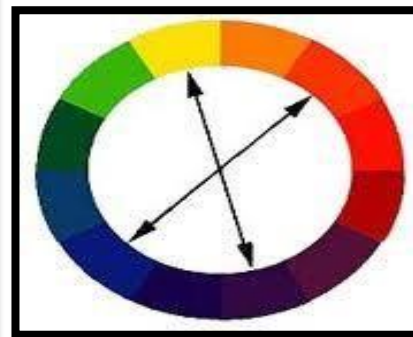
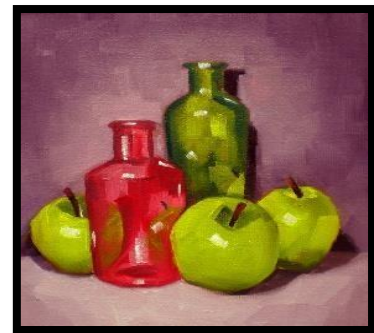

1.4.4 Analogous Color

These colors are located next to each other on the wheel, such as:

- Blue, Blue-green, Green
- Red, Red- Orange, and Orange

Analogous colors are sometimes called harmonious colors. This combination of colors provides very little contrast. Analogous colors are illustrated here: yellow, yelloworange, orange and red - orange, Red.



1.4.5 Neutral Colors:

The neutral colors contain equal parts of each of the three primary colors. Black, white, gray and sometimes brown are considered "neutral".

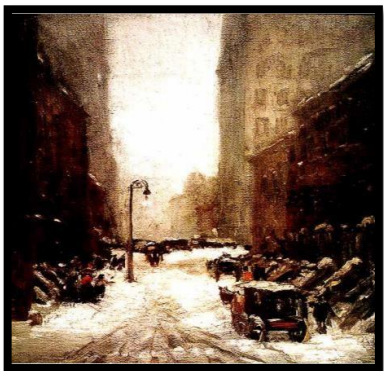

Point to Ponder!

There are a few different ways to make neutrals. You can blend black and white to make gray. You can create brown in two ways by blending two complementary colors together or by blending all three primary colors together.

Do you know?

Neutrals don't usually show up on the color wheel.

1.4.6 Monochromatic:

A monochromatic scheme consists of different values (tints and shades) of a single color. An example of a monochrome color scheme could include any color mixed with white or black. The example below is a green monochromatic color scheme.

- A shade of green is made by mixing green and black.
- A tint of green is made by mixing green and white.

**Do you know?**

“Mono” means “one”,
 “chroma” means “color”
 Monochromatic is one
 color used with different
 values and intensity.

**Activity:**

- ❖ Develop a design, based on nature and apply 8/8inches monochromatic colour scheme on it

Material required:

- Pencil
- Eraser
- Sharpener
- Poster colors
- Pencil colors
- Paint brushes
- Paint palette
- Figure / Diagram

**Procedure:**

- Draw a square of 3/3
- Using different shapes drawn from nature create a design
- Making the repeat of the block
- Make a colour scheme of monochromatic colours

1.4.7 Triadic:

A triad color scheme uses three colors that are evenly spaced around the color wheel. Triad color schemes tend to be quite vibrant, even if you use pale or unsaturated versions of your hues. To use a triad scheme successfully, the colors should be carefully balanced. Let one color dominate and use the two others for accent.

It refers to three colors that are evenly spaced on a color wheel.

1.4.8 Tetradic:

The rectangle or Tetradic color scheme uses four colors arranged into two complementary pairs.

This rich color scheme offers plenty of possibilities for variation.

The Tetradic color scheme works best if you want one colour to be dominant.

You should also pay attention to the balance between warm and cool colors in your design.

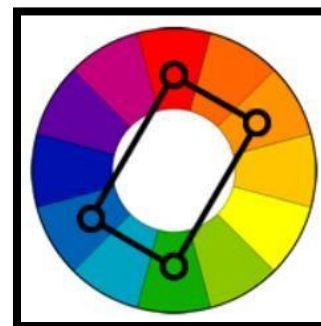
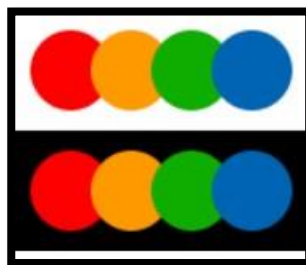
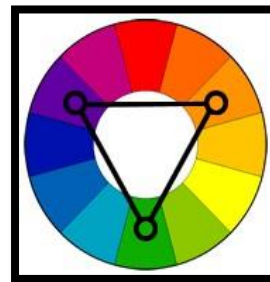
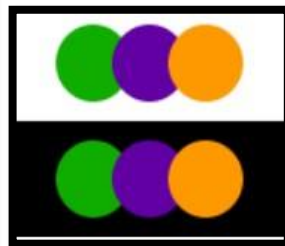

Activity:

- ❖ Make Geometrical designs on FOUR boxes of 3/3 inches squares
- ❖ Develop color schemes/combinations in Complementary, split complementary, Analogous and Neutral colors.
- ❖ Apply all Four color schemes in each box

Material required:

- Pencil
- Eraser
- Sharpener
- Poster colors
- Water color brushes
- Water color Palette
- Ruler

1.5 Characteristics of Colors

Colors have three main characteristics:

- **Hue:**

Hue is one of the main properties of a colour. A hue is referred as a pure colour i.e. without the addition of white or black. Colours like red, yellowgreen, magenta etc. are some examples of hues.



- **Value:**

The value is the measurement of the lightness or darkness of a colour, lighter colour has higher value and it emits

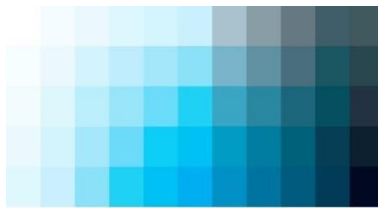

more light. For example, the yellow is brighter than dark blue therefore the value of yellow is higher than blue.

Interesting Information

- Color values are the lights and darks of a color you create by using black and white ('neutrals') with a color. This makes hundreds of more colors from the basic 12 colors of the wheel

1.6 Tints and Shades

Shade and tint are terms that refer to a variation of a hue.

□ Tints:

Tints are lightened colors that are produced by the addition of white.

□ Shades:

Shades are darkened colors that are produced by the addition of black.

This painting by Vincent Van Gogh, *Fields in a Rising Storm*, has tints and shades of blue in the sky, and tints and shades of green in the fields.



Value Scale of Tints

Value Scale of shades

Interesting Information

- Tonal gradation is the gradual transition from one shade to another for example from rust to dark brown or light rust

1.7 Intensity

Intensity refers to the brightness or dullness of a color. Adding gray to a color makes it dull. That means a brighter colour has a higher intensity as compared to a dull colour.



Do You Know?

Intensity, saturation and value are inter-related terms and have to do with the description of a color.

Example of Monochromatic Color Scheme.

A color scheme made up of shades, values, and tones of one color.

Activity:

- ❖ Develop designs in THREE boxes of 3/3 inches squares using circles and triangles
- ❖ Apply tints and shades colors in 1st Box
- ❖ Apply Hue and Value in 2nd box
- ❖ Apply Intensity colors in 3rd box

Material Required

- Pencil
- Eraser
- Sharpener
- Poster colors
- Water color brushes
- Water color Palette
- Compass
- Ruler
- Ruler

1.8 Different colour terms for developing Designs

It becomes easier to use colour in a design by using some basic guidelines. It is advisable to use fewer colours in a instead of a lot of colours at once. Using a combination of warm and cool colours is a good option. For best design make use of appropriate balance color dimensions or color schemes. Never use too much contrasting colors. Red, blue, and yellow are known as the primary colours. All other colors come from a combination of these three hues. Primary colours can work great for a monochromatic colour schemes.

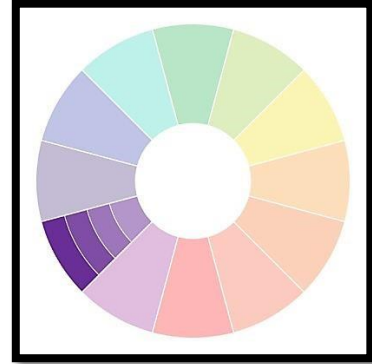

1.8.1 Combining Patterns:

Combining patterns is always interesting step in design. For colors with different intensity and value. Using different texture can draw attention.



1.8.2 Combination of two/ three color schemes:

Color schemes are set method of choosing colors that relate in some way to each other and look good together. Combing two or three color schemes is always a difficult task. Choose appropriate tone and intensity of colors. If chosen carefully the whole composition will look great.



blending patterns always choose a lead pattern. Draw patterns with different scales and variations. Patterns should complement each other, use

Activity:

- ❖ In the pictures below, you will find examples of many of the colors on the color wheel. Answer the questions that go with each picture.
- ❖ This painting, called Landscape at Ceret, was painted by the Spanish artist Juan Gris.

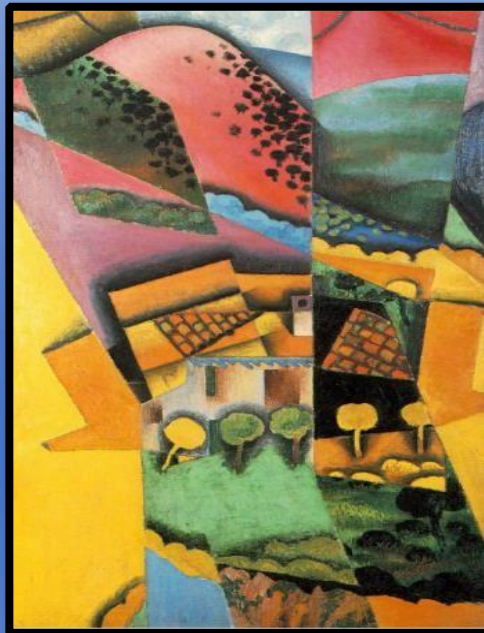

In the painting:

1. Identify six places where you see the three primary colors.
 2. Then, identify two places where you see two primary colors next to each other.
 3. Place a checkmark on two places you see a primary color adjacent to a secondary color.
 4. Circle a place you see a shade of blue.
 5. Circle a place you see a tint of green.
- What colors do you see here?**
- List the three colors you think the artist used most in this painting.**

Activity:

- ❖ Explore different types of patterns and develop a design.
- ❖ Apply colors in these designs using monochromatic, complimentary, split-complimentary and analogous color schemes.

Material Required:

- Pencil
- Eraser
- Sharpener
- Poster colors
- Water color brushes
- Water color Palette
- Compass
- Ruler
- Ruler

Procedure:

1. Make boxes of size 3" x 3".
2. Make thumbnails of different patterns in each box.
3. Make a box of size 6" x 6".
4. Compose a design based on different patterns in this box and apply different color schemes using poster paints

Color Vocabulary-Assessment

1. The chart that shows the relationship of different colors to each other is called the _____.
2. Instead of the word "color," one could also use the three-letter word _____.
3. The three colors from which all other colors are made are called _____ colors and they are _____, _____, and _____.
4. Colors that are created by mixing equal parts of the colors above are called _____, and they are _____, _____, and _____.
5. Colors that are created from equal parts of each of the two kinds of colors above are called intermediate or _____ colors.
6. When describing these colors, place the _____ color first.
7. Colors that are next to each other on the color wheel are called _____.
8. Colors that are opposite to each other on the color wheel are called _____.
9. If you add white to a color, that is called a _____.
10. If you add black to a color, that is called _____.
11. If something only uses one color, it is called _____.
12. The colors on the green/blue/violet side of the color wheel are called _____.
13. The colors on the red/orange/yellow side of the color wheel are called _____.

Color Vocabulary Assessment Key:

1. color wheel
2. hue
3. primary
4. red, yellow, blue (no order necessary)
5. secondary
6. green, orange, violet (no order necessary)
7. tertiary
8. primary
9. analogous
10. complementary
11. tint
12. shade
13. monochromatic
14. cool
15. warm

- All the colors on one half of the color wheel.
- The color adjacent to the primary colors.

Color theory-Vocabulary Review

- **Color Wheel:** This is the basis of color harmony. The wheel encompasses various aspects of color theory, which assists artists to make strategic color decisions.
- **Primary Colours:** Red, yellow and blue make up this color group. These colors are used in combination to create all other colors.
- **Secondary Colours:** Green, orange and purple make up this color group. These colors and the primary colors make up the color wheel.
- **Tertiary Colors:** These are the colors that lie between the primary and secondary colors. They are made by mixing a primary color secondary color. They are made by mixing a primary color and a secondary color. These include yellow-green, blue green, red-violet and others.
- **Analogous Colours:** These colors are a series of three colors /shades that appear side by-side on the color wheel, such as red, red-orange and orange, for by side on the color wheel, such as red, red orange and orange, for example. The colors in this group always have one color in common.
- **COMPLIMENTARY Or CONTRASTING COLORS:** Colors that are directly across from each other on the color wheel -for example, blue and yellow, red and green
- **WARM COLORS:** These colors occupy roughly the right side of the color wheel, from red to yellow-green. They appear to be representing “hot temperatures”.
- **Cool Colors:** These colors are those on the left side of the Color Wheel, from purple to green. These colors appear to be “representing cool temperatures”.
- **NUETRAL COLORS:** White black, gray and brown.
- **MONOCHROMATIC COLORS** a color scheme made up of shades, values, and tones of one color.

1.9 Basics of Design

This topic is concerned with understanding the basic concepts of design; How to analyze and talk about visual language. These fundamental components are known as the principles and elements of design.

Do You Know?	Do You Know?
Drawing is all about how you perceive the world around you and how you interpret it into your own personal vision.	Design is the process of selecting and Organising elements or components in order to fulfill a specific purpose. This purpose may be functional or aesthetic, or (frequently) both

1.9.1 Elements & Principles of Design

The elements and principles of design are the building blocks used to create a work of art. The **elements** of design can be thought of as the things that make up a painting, drawing, design etc.

The **principles** of design can be thought of as what we do to the elements of design. How we apply the principles of design determines how successful we are in creating work of art

□ Elements of Design

The elements are components or parts which can be isolated in any visual design or work of Art. They are the structure of work and can carry a wide variety of points.

The following elements are the building blocks of design.

1. Line
2. Shape
3. Form
4. Colour
5. Texture
6. Space

Interesting Information

- Designer who knows the design Elements & Principles can evaluate the design in terms of line, color, balance, texture, etc. Design Elements and Principles proves to be an analysing frame for the designers.

THE ELEMENTS OF DESIGN

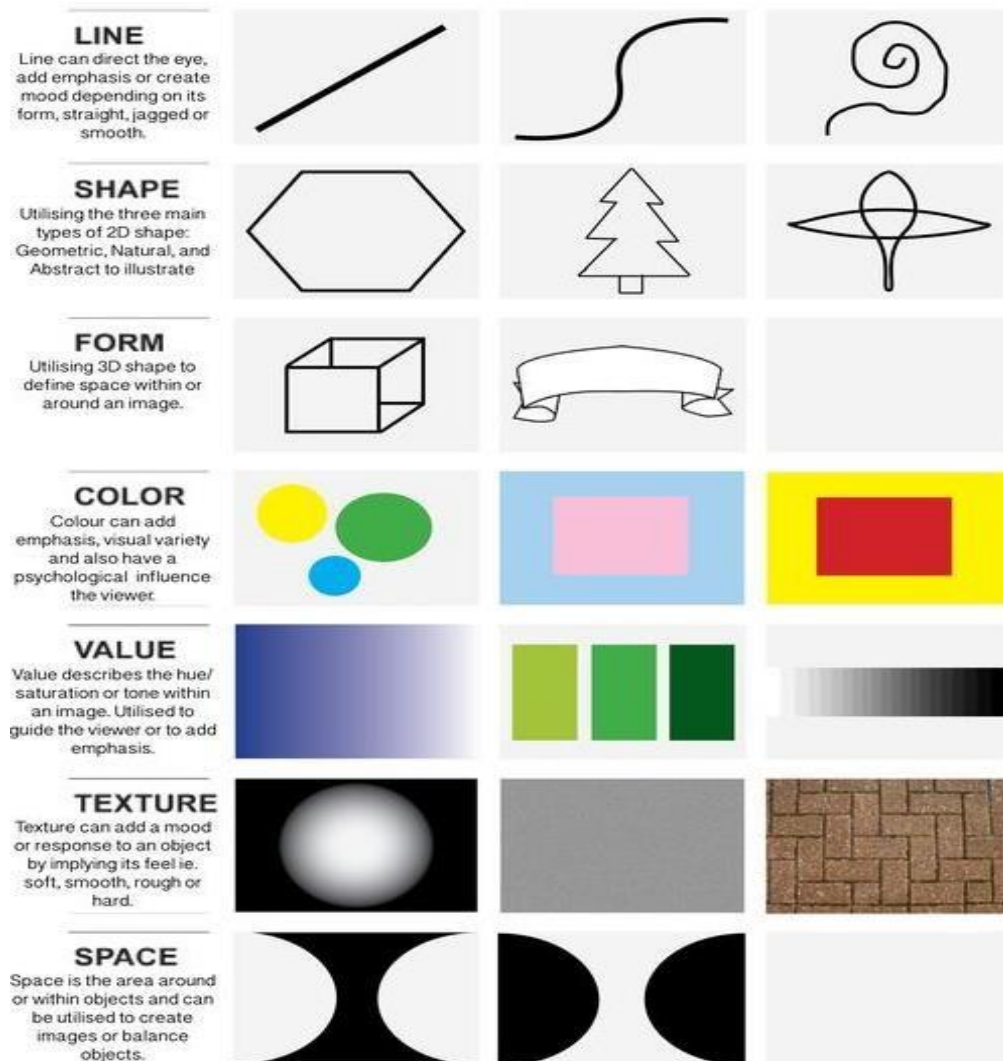

○ Lines

Line is a mark on a surface that describes a shape or outline. It can create texture and can be thick and thin. Types of line can include actual, implied, vertical, horizontal, diagonal and contour lines. Line can be two-dimensional (a pencil line on paper), or implied three-dimensional

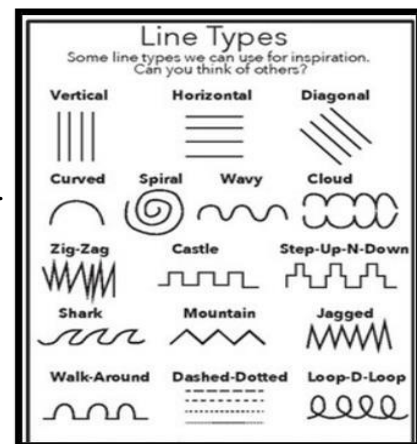

Interesting Information

- Line is not necessarily an artificial creation of the artist or designer; it exists in nature as a structural feature such as branches, or as surface design, such as striping on a tiger or a seashell.

Types of lines

There are different types of lines:

a) Horizontal Lines:

Horizontal lines are parallel to the horizon. Going right to left or left to right is called horizontal. They look like they're lying down, at rest, asleep. They suggest calm and quiet, a relaxed



comfort. Horizontal lines by their connection to the horizon are associated with earth bound things and idea.

Do You Know?

Horizontal lines can't fall over. They accentuate width. They're stable and secure. They convey an absence of conflict, a restful peace.

b) Vertical Lines:

The distance between the highest and lowest points of a sky area and up down lines is called vertical lines. Vertical lines are awake, alert; defy gravity, rigid, firm, stable, and strong. Their tallness and formality may give the impression of dignity.

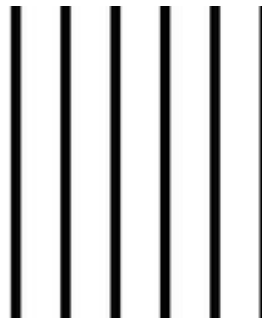

c) Curved lines

Curved lines are softer than straight lines. They sweep and turn gracefully between end points. They are less definite and predictable than straight lines. They bend, they change direction. Curved lines express fluid movement. They can be calm or dynamic depending on how much they curve. The less active the curve the calmer the feeling.



d) Diagonal lines

Diagonal lines are unbalanced. They are filled with restless and uncontrolled energy. They can appear to be either rising or falling and convey action and motion.

Diagonal lines are more dramatic than either horizontal or vertical lines.



active. They imply

movement, tension, sometimes violence.

Their apparent movement creates tension and excitement. These lines are the most

e) **Natural lines** A mark with length and direction that forms an irregular shape or one that might be found in nature, rather than a regular, mechanical shape



f) Independent lines

Independent lines are free hand lines free from any boundaries and set rules.



g) Combined lines

Combined lines are a combination of different lines that connect at points for example combining curve lines with straight and diagonal lines.

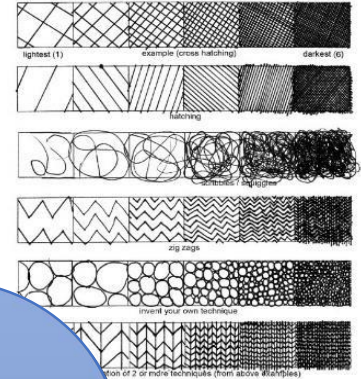

Activity:

❖ Lines in a Mechanical way

Material Required

- Pencil
- Eraser
- Sharpener
- Ruler

Procedure

Make a table of size 10”X10”.

Draw 9 squares of 3/3 inches with the distance of 0.5” between each box of the table.

Draw following lines in each box:

Horizontal Lines

Vertical Lines

Diagonal Lines

Curvilinear Lines

Close Horizontal Lines

Close Vertical Lines

Cross hatching with horizontal & vertical lines

Cross hatching with diagonal lines

Cross hatching with Curvilinear Lines







The lines must be accurately made with uniform distances between them

<u>Vertical Lines</u>	<u>Horizontal Lines</u>	<u>Diagonal Lines</u>
<u>Curvilinear Lines</u>	<u>Close Vertical Lines</u>	<u>Close Horizontal Lines</u>
<u>Cross hatching with horizontal & vertical lines</u>	<u>Cross hatching with diagonal lines</u>	<u>Cross hatching with curvilinear lines</u>

O Shape

Shape is a self-contained defined area of geometric or organic form. A positive shape in a design automatically creates a negative shape. Shapes can be divided into several types:

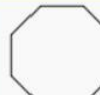
Geometric (square, triangle, circle) and organic (irregular in outline)

Triangle 3 Sides	Square 4 Sides	Pentagon 5 Sides	Hexagon 6 Sides
			
Heptagon 7 Sides	Octagon 8 Sides	Circle 0, 1, ∞, ?	
			

Cubical Shapes



Organic Shapes

Categories of Shapes

- I. Cubical Shapes
- II. Round Shape

I. Cubical Shapes

Cubical means shape like a cube. A cube can define in 2D as well as in 3D shape. A shape which has edges is called cubical shape e.g. Square, triangle, rectangle

Types of Cubical Shapes Square:

Square is geometric shape it has four equal sides, equal angles and equal dimensions. It gives more stable and restful feeling.

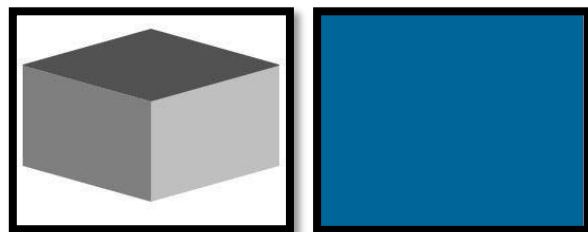

Triangle:

A triangle is one of the basic shapes of geometry with three corners having two angular sides and one horizontal base.

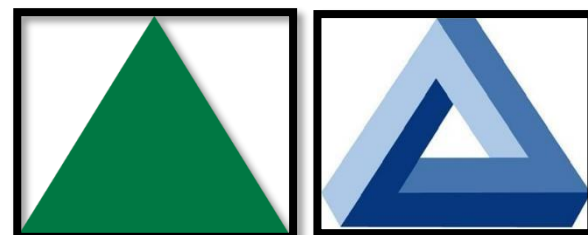

Rectangle:

Rectangle is a geometric shape with two sides equal in length and

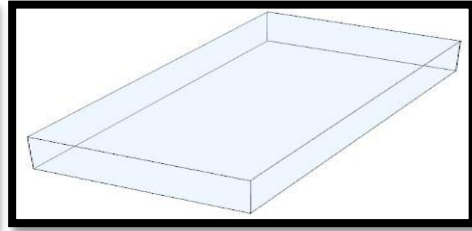

having equal angles. Rectangle gives width to the object.

II. Round Shapes:**Circle:**

Circle has no corners and its curves are equally distanced from the center point.

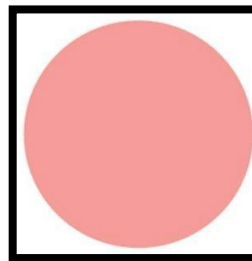
**Oval:**

Oval is a closed curve lines resemble to the shape of egg.

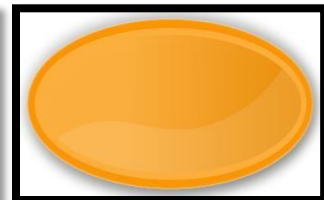
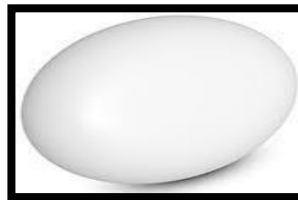
**Sphere:**

A sphere is a perfectly round geometrical and circular object in three dimensional space that resembles the shape of a completely round ball.

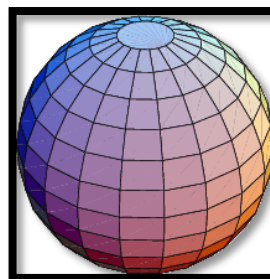
**Do You Know?**

Shape is an enclosed space, the boundaries of which are defined by other elements of art (i.e.: lines, colors, values, textures, etc.) and they are limited to two dimensions.

Activity:

- ❖ Make a design using shapes

Material required:

- Pencil
- Eraser
- Sharpener
- Poster colors
- Water color brushes
- Water color Palette

Procedure:

1. Make a big circle.
2. Now add a star in the center of the circle of seven corners.
3. Now add one more star behind the first star slightly tilted from the first one.
4. Add two more stars slightly smaller inside the first star.
5. Now color the designed based on shapes with suitable colors.

Interesting Information**Difference between shape & form**

1. Shapes are the most basic figures like rectangles, circles, triangles, and squares while forms are the more complex structures like sphere, cube, cone, etc.
2. Shapes are in 2D (have length and width) while forms are
3. in 3D (have length, width, and height).
4. Shapes are far simpler figures compared to the more complex forms.
5. Shapes exist in the space of flat and simple drawings, printings, and painting surfaces while forms exist beyond the space of shapes e.g. metal work, pottery, sculpture

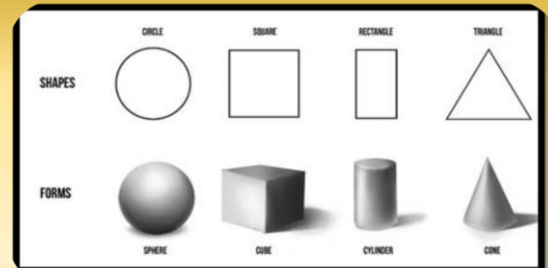

□ **Form**

Forms describes volumes and mass, or the 3D aspects of objects that take up space. Forms can and should be viewed from any angles. For example when you hold a ball, or a small sculpture, you are aware of their curves, angles, indentations, & edges.

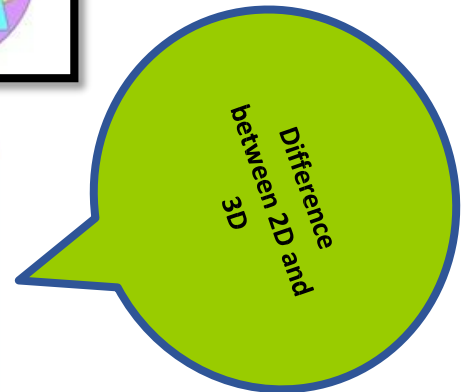
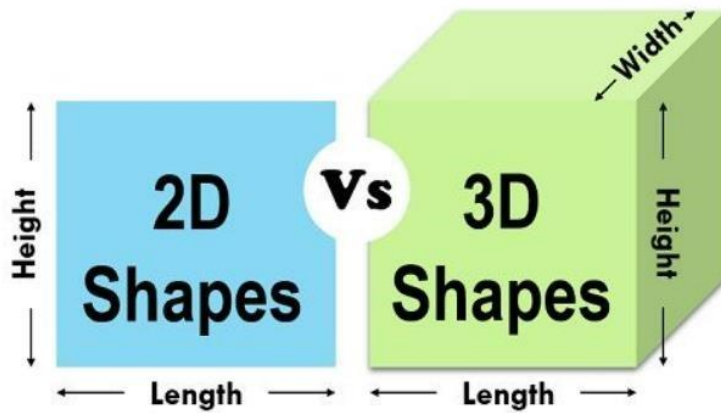
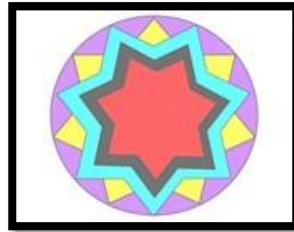
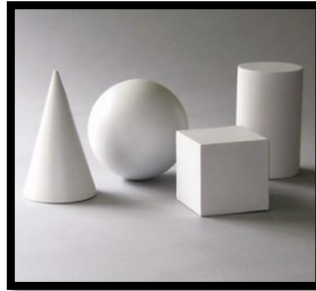

Geometric forms

Geometric forms are those which correspond to named regular shapes, such as squares, rectangles, circles, cubes, spheres, cones, and other regular forms. Architecture is usually composed of geometric forms. These forms are most often thought of as constructed or made.

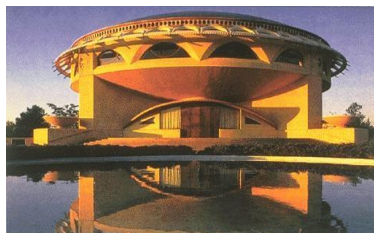

Activity:

Make a design using geometric forms

Material required:

- Pencil
- Eraser
- Sharpener
- Poster colors
- Compass

Procedure:

1. Make Four boxes of size 3''x 3''.
2. Make thumbnails of different types of geometric forms/shapes in each box.
3. Make a box of size 6'' x 6''.
4. Compose a design based on geometric forms in this box and paint it using poster paints/ pencil colors.

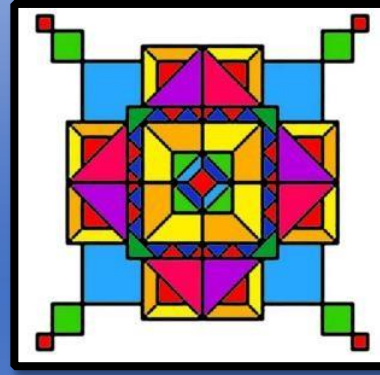
 **Space:**

Space is the empty or open area between, around, above, below, or within objects. Shapes and forms are made by the space around and within them. Space is often called three-

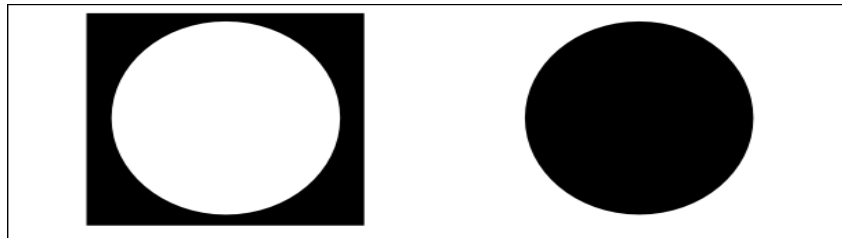

dimensional or two- dimensional. Positive space is filled by a shape or form. Negative space surrounds a shape or form.

 Texture:

The word texture means: what things are made of and how they feel as if you could feel if touched

The feel, appearance, or consistency of a surface or a substance. Texture may be rough, smooth, soft or fussy, stiff or course. For example, texture of a fabric, texture of wall etc.

Anyone can find texture in different ways. i.e.

a) **Natural texture**

It's the texture we find and it is not made by humans. For example: stones, sand, rice, etc.

b) **Artificial texture**

It's the texture from things made by humans. For example: a pencil, a chair, a raincoat, etc.

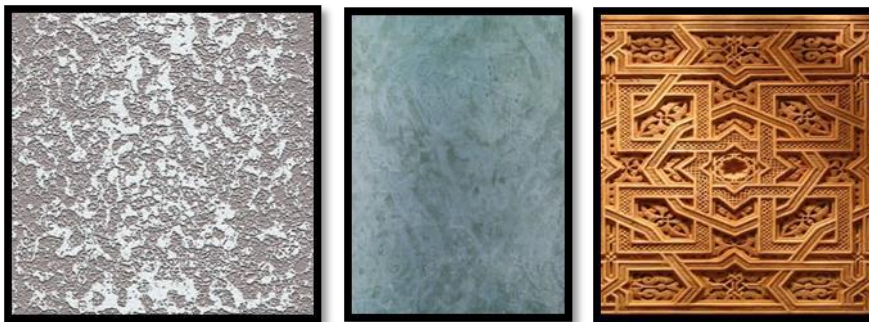

Principles of Designs

Basic design principles are used to organise or position the structural elements of design. These principles are the fundamental concepts that will assist you to communicate the key theme of your composition. As such they can be applied to each element of your design or to your composition as a whole. It is necessary to develop a visual awareness to identify how these principles are used in the composition of every day design e.g. in illustrations, photographs, paintings, textile design, posters etc. Developing a visual awareness will give you the skills necessary to critically analyze and constructively criticize the design work you engage in. This will allow you to develop a method of solving graphic problems in reference to the following basic principles of design. Given below are the basic principles of design:

- I. Balance
- II. Proportion
- III. Rhythm/Harmony
- IV. Emphasis
- V. Composition
- VI. Unity

□ Balance

Balance is a feeling of visual equality in shape, form, value, color, etc. Balance can be symmetrical or evenly balanced or asymmetrical and un-evenly balanced. Objects, values, colors, textures, shapes, forms, etc., can be used in creating a balance in a composition.

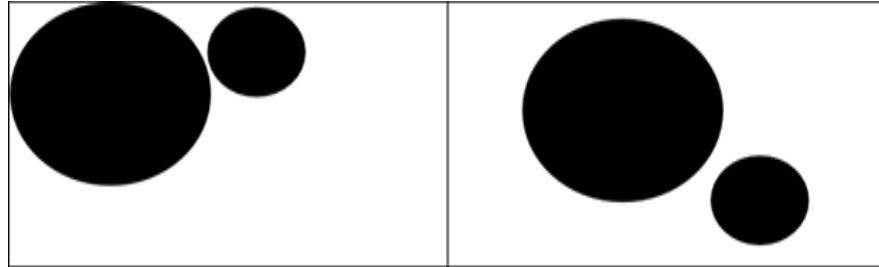

Interesting Information

- As a design principle, balance places the parts of a visual in an aesthetically pleasing arrangement. It is the distribution of elements across the design. Balance provides stability and structure to a design.

Types of Balance

Balance is of two types:

- Formal Balance (Symmetrical)
- Informal Balance (Asymmetrical)

□ Formal Balance (Symmetrical)

In formal balance elements of designs are equally distributed across both sides of a design in terms of number, shape, colour etc. Butterfly is the best example of formal balance. It is created by repeating the reverse of a design on the opposite side of the vertical axis; each side, in essence, becomes the mirror image of the other. Symmetrical balance is considered formal, ordered, stable and quiet. It is often used in architecture.

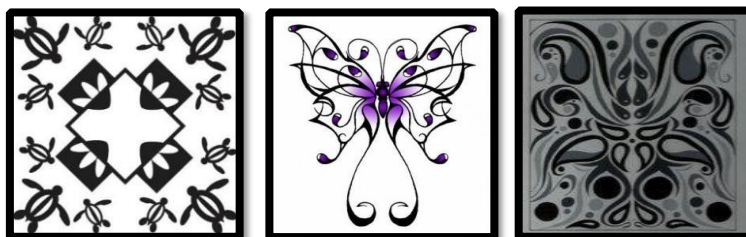

□ Informal Balance (Asymmetrical)

Asymmetrical, or informal balance, involves different elements that have equal visual weight; the weight is equal but the elements are not identical. Asymmetrical balance is casual, interesting and more dynamic than symmetrical balance. Informal balance occurs when several smaller items on one side are balanced by a large item on the other side, or smaller items are placed away from the center of the screen than larger items

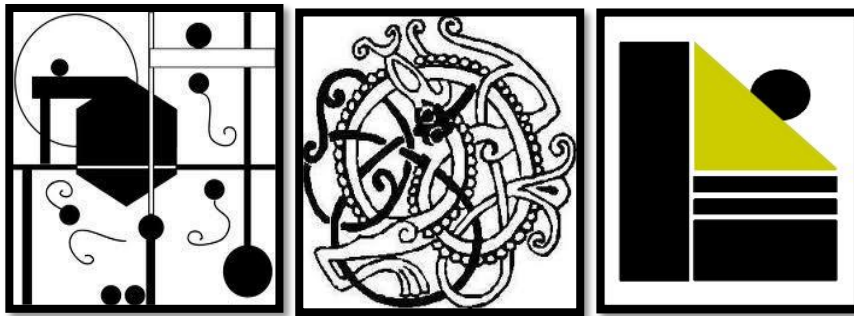

Activity:

- ❖ Create a design based on symmetric balance of design

Material required:

- Pencil
- Eraser
- Sharpener
- Poster colors
- Pencil colours
- Ruler

Procedure:

1. Draw a square of 5 /5
2. Make the half of the square
3. Draw the same design on both sides
4. Colour the design
5. One half design should be black in design and back ground be white
6. Other half back ground be black and design should be .white

Point to Ponder!

Which type of balances are shown in these pictures?

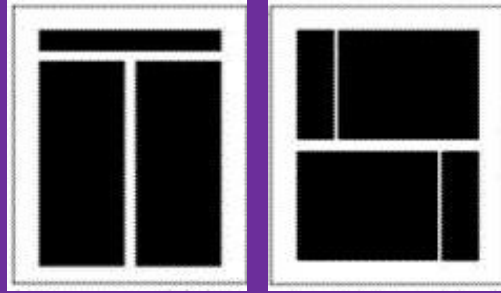
**□ Proportion**

Proportion refers to the size and scale of elements of designs. Proportion is the relationship of two or more elements in a design and how they compare with one another. Proportion is said to be harmonious when a correct or desirable relationship exists between the elements with respect to size, color, quantity, degree, or setting. Good proportion adds harmony, symmetry, or balance among the parts of a design.

**□ Rhythm Harmony**

Rhythm refers to the organised movement in design with respect to space and time. It depicts the flow in a design and directs eye movement. Harmony in a design means all parts of the visual image relate to and complement each other. It pulls the pieces of a visual image together.



Activity:

- ❖ Rhythm and Harmony of a design

Material required:

- Pencil
- Eraser
- Sharpener
- Poster colors
- Pencil colours
- Ruler

Procedure:

1. Before making a complete design, a small key is first drawn.
2. To make the key of the design, draw a box of size $4/4$ ".
3. Draw any design in the key
4. After making design in the key, make a box of size $8/8$ ".
5. Trace the key template in the first box and then flip the design in the second box next to it.
6. Now again repeat the design in the box just below the 2nd box and flip the design for the last time again in the last remaining box just below the 1st box.
7. The desired block repeat is achieved.

□ Emphasis

Emphasis creates a focal point in a design; it is how we bring attention to what is most important. Emphasis is what catches the eye and makes the viewer stop and look at the image. Without emphasis, without getting the viewer to

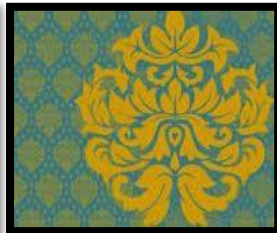
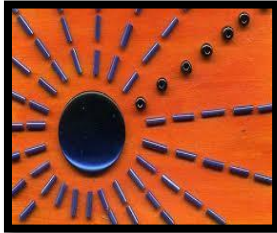

look at the image, communication cannot occur.



Activity:

- ❖ Emphasis of a design

Procedure:

1. Create a self-design using some pattern
2. Use a block repeat technique
3. Create a focal point in your design
4. Draw a bold motive to create emphasis in your design
5. Use complementary colour to bring emphasis in your design

□ Composition

Composition means “putting together”. It is organizing different elements in a design to give wholeness. A composition is the arrangement of visual elements in a picture or a design. It can be things like the angle of the point of view in a figurative picture or it can be more abstract elements like the placement of light and dark areas or the placement and angle of lines which can keep your attention focused on the page (or canvas) or lead your eye straight off in some direction if badly done.



□ Unity

A way to bring a piece together by using similar elements throughout. It refers to the arrangement of elements to give the viewer the feeling that all the parts of the design or piece form a coherent whole i.e. designs must be in harmony in which all sections of the pattern make other sections feel complete. It enables the design to be seen as one complete piece of art or design.



Different types of Designs

- Geometric
- Floral
- Abstract

□ Geometrical Design:

Geometric designs are one of the most visually appealing forms in different fields of design. They can appear in a wide variety of styles and fulfill a huge range of roles.

At its core, design is based on shapes. Geometric shapes design with circles, triangles, squares, rectangles, and many other shapes often combine to form beautifully intricate patterns.

Even if you only use a few shapes in your design, there are so many possibilities as to what you can create. The Most Common Types of Geometric Shapes ✓ The square/rectangle.

- ✓ The circle
- ✓ The triangle
- ✓ The hexagon.



How to make a beautiful design in Circle shape:

To make this beautiful design in Circle above you have to just follow the following steps:

Step 1: Make a big circle as shown in picture.

Step 2: Now insert a big star shape in the circle of seven corners as shown in picture.

Step 3: Now make a same star on it just slight turn it as shown in picture.

Step 4: Now no need to turn what we made above make it similar but smaller than it as shown in picture.

Step 5: Once more you have to make a same star just a little smaller than it as shown in picture. Now your beautiful design in Circle shape is ready to color.

Step 6: So your Circle shape beautiful design is ready with beautiful colors.

**Key Points**

- Importance of Color Theory in drawing and Design
- Difference between Primary, Secondary and Tertiary Colors
- Understand different Color Schemes/Combinations
- Characteristics of Colors (Hue, Value and Chroma)
- Different color terms for developing design
- Elements of Design
- Principles of Design
- Types of Design
- Use of Different media and materials

Web Links

- <https://www.interaction-design.org/literature/topics/color-theory>
- <https://artclasscurator.com/principles-of-design-examples/>
- <https://design.tutsplus.com/articles/what-is-geometric-design-design-in-60-seconds-cms-28079>

EXERCISES**Tick (✓) the most suitable option**

1. **How many Primary Colours are there in the Colour Wheel?**
 - a) Two
 - b) Three
 - c) Four
 - d) Six
2. **Secondary Colours are**
 - a) look like the primary ones but are not quite the same.
 - b) opposite to each other on the color wheel.
 - c) result from mixing two primary colors together.
 - d) next to each other in the color wheel.
3. **What do you get mixing two secondary colors together?**
 - a) A Triadic Color Scheme
 - b) A Neutral Color or a Gray
 - c) A rainbow
 - d) A messy muddy color
4. **Primary Colours are:**
 - a) Yellow, red, and violet
 - b) Yellow, red, and blue
 - c) Orange, red, and blue
 - d) Black and white
5. **What are complementary colors?**
 - a) Opposite to each other
 - b) Parallel to each other
 - c) Beside each other
 - d) Similar to each other

6. **Texture is**
 - a) Practical
 - b) Tactile
 - c) Unreal
 - d) Conceptual
7. **Triad Colour Scheme comprises of**
 - a) 5 colours
 - b) 3 colours
 - c) 4 colours
 - d) 2 colours
8. **Space is**
 - a) positive area of the design
 - b) colour of the design
 - c) negative area of the design
 - d) principle of design
9. **Emphasis means**
 - a) New point
 - b) Different point
 - c) Special point
 - d) Focal point
10. **Horizontal lines are parallel to**
 - a) Horizon
 - b) Lines
 - c) Space
 - d) Emphasis

Write Short Answers

1. What is the importance of colour theory?
2. What is a tetrad colour scheme?
3. What do you mean by elements of design?
4. What is the difference between Primary and Secondary Colours?
5. Explain types of texture with examples.
6. What is the difference between 2D and 3D? Explain with examples.

Extended Response Question

1. What are the principles of design? Describe each principle with examples.
2. Write down the basics of Design
3. Name different types of colour schemes. Explain any two in detail.
4. What is meant by the term “shape”? Write down the characteristics of three different shapes.

Constructed Response Question

Our world is a galaxy of Colours. You can find thousands of Colours around you. Match the following Colours with Night and Sunlight Colours. How did you match them with these two contrasting concepts? Give reasons.

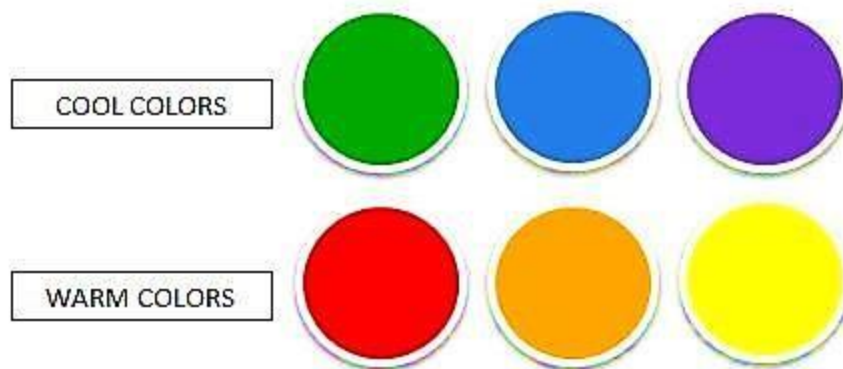

Project:

- ❖ Elements and Principles of design matrix

Objectives

- To develop an understanding of elements and principles of drawing and design.
- To know how they can be incorporated making a design.
- To be able to apply elements and principles of design in any kind of design

Material Required

Pencil, Eraser, Sharpener, Ruler, Poster paints, Pencil colors, Pointers

Figure / Diagram / Sketch

		Principles of Design			
		Balance	Rhythm/ Harmony	Emphasis	Composition
of design Elements	Line				
	Shape				
	Form				
	Space				
	Pattern				
	Texture				
	Color				

Procedure

- Draw a table with six columns and eight rows.
- Draw every element over each column of the table.
- Draw every principle in the beginning of each row of the table.
- Start making designs by combining an element with a principle e.g. make a design using line in balance.
- Apply colours in colour part

Note: You can make any kind of designs/drawings to incorporate elements and principles of designs

FASHION DRAWING-I



5

Why Croquis important in fashion design?

Is the human body elongated to make an illustration?

How can fashion be depicted with visuals?

Describe the process of drawing feet

After studying this unit students must be able to:-

- describe about the basics of fashion drawing/illustration
- explain the process of drawing basic 9head fashion figure/croquis
- understand the process of drawing basic 10head fashion figure/croquis
- apply the process of drawing basic 9head and 10 head fashion figure
- recognize about the basic human anatomy
- describe the process of drawing head with different hairstyles
- describe the process of drawing hands
- describe the process of drawing arms

Fashion Drawing - I

Fashion has become a very important aspect of our lives. We use it to look good and show our personal style. Fashion designers need to sketch out their ideas to better visualize their designs.

Basic Fashion Sketches

Basics of Fashion Drawing/illustrations:

Fashion drawing/illustration is a sketch of the human figure showcasing your clothing design, the style of clothing and embellishments as well as the attitude or general feel you want to convey with that particular style.

The fashion sketch can be a quick sketch or outline suggesting the basic silhouette or it can be a detailed illustration showcasing the color combinations, embellishments, darts, pockets positions, etc. and the accessories supporting the look. Sometimes thm.

Oh No, But I cannot draw? And I want to be a fashion designer!

Fashion Drawing is a skill and not necessarily a talent. Skill can always be improved upon. Anyone can learn to draw with proper practice and diligent hard work. So not knowing drawing should not be an excuse not to pursue your dreams.

Fashion Croquis

The first step in fashion figure drawing is to create a fashion croquis. A croquis is a quick sketch outlining the proportions of the fashion figure. A croquis is almost like a paper doll, it is a template and can be placed under a piece of paper for drawing garments. Fashion croquis can be all different shapes, sizes, and styles. It all depends on the end use of your design and the demographic you are designing for.

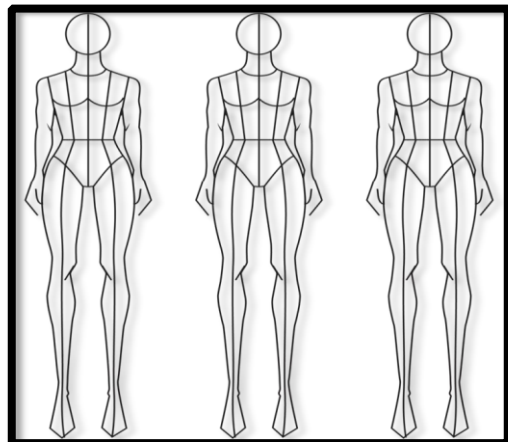

Process of drawing basic 9 heads fashion figure

The standard Croquis is an elongated figure with longer legs, a smaller head, and thinner hips than the average woman. The croquis is 9 heads tall from the top of the head to the ankles. (The feet are excluded from the equation since they can vary in height depending on type of shoes and heel height.) The point of view is that a fashion model's length and simplicity of form help to display clothing with a dramatic effect. The design intent of a garment is exaggerated when displayed on an elongated scale, and this elongated scale helps to portray a fantasy.



Things to Remember while Studying Fashion

- Balanced approach and originality
- Portfolio development
- Talk to your peers
- Stay in touch with latest trends.
- Research
- Know latest technologies
- Internship

Application Process of Drawing Basic 9 head and 10 head

Part 1: Creating Guidelines

Step 1: Draw 9 heads that are roughly the same shape and size and label 1 -9. leave some space at the bottom of the page for the feet.

Step 2: Draw horizontal lines between each head (make sure they are straight)

Step 3: Add a dashed line at roughly $1\frac{1}{2}$ and $4\frac{1}{4}$ heads

Step 4: Label anatomy as marked on this page

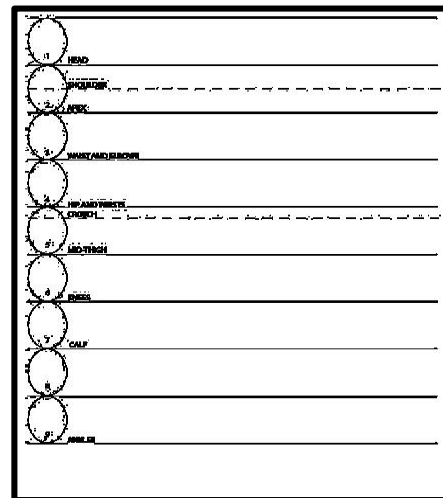
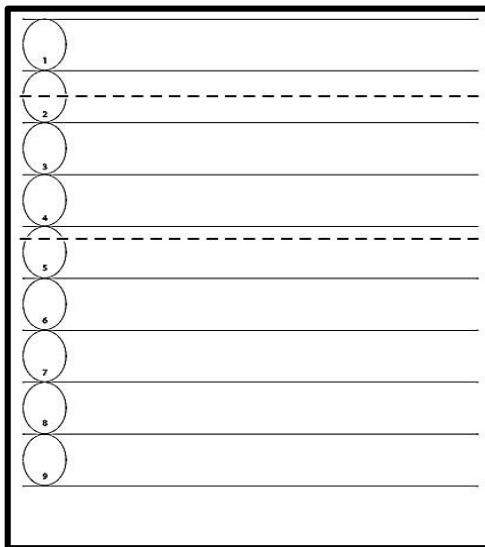
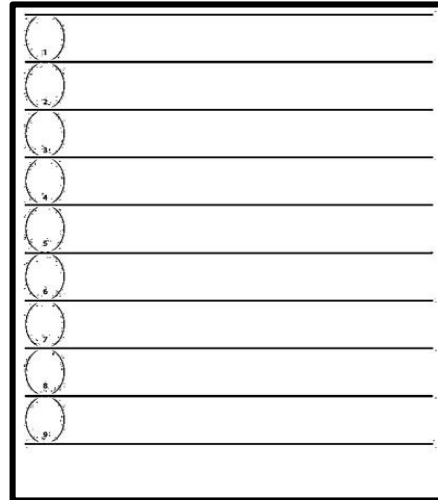

Do You Know?

10 headed fashion figure is also used in the fashion drawing, the Process is almost same as discussed below in the 9 headed Croquis.

Part 2 Drawing the Croquis

- Step 1:** Draw a vertical line, perpendicular to the horizontal guidelines. This will be the center line
- Step 2:** Draw an oval for the head
- Step 3:** Draw a horizontal line for the shoulders (roughly 2" heads wide)
- Step 4:** Repeat step 3 for the hips (the hips and shoulders are the same width)
- Step 5:** Draw a horizontal line for the waist (roughly 1 head width)
- Step 6:** Connect the shoulder, waist and hips
- Step 7:** Draw a guideline for the arms as pictured
- Step 8:** Draw a vertical line from the waist down
- Step 9:** Draw a cylinder for the neck
- Step 10:** Connect the neck to the shoulder
- Step 11:** Draw small ovals for the knees
- Step 12:** Draw small ovals for the ankles

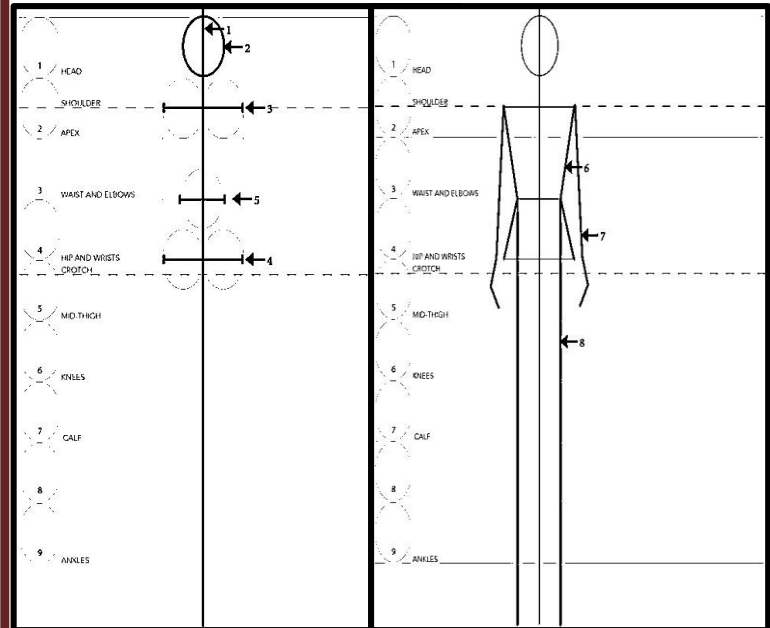

Part 3: Adding Shapes

- Step 1:** Draw ovals for the shoulder, bicep, and lower arm
- Step 2:** Draw ovals for the upper and lower leg
- Step 3:** Draw triangles for the feet
- Step 4:** Add shape to the neck and outline the arm, using the ovals as guidelines. Repeat on other side
- Step 5:** Outline the leg and foot as illustrated, using the ovals as guidelines. Repeat on other side
- Step 6:** Add neck, bust, and pelvic line as illustrated.
- Step 7:** Add center line at each side of body as illustrated. This is called the "princess line."

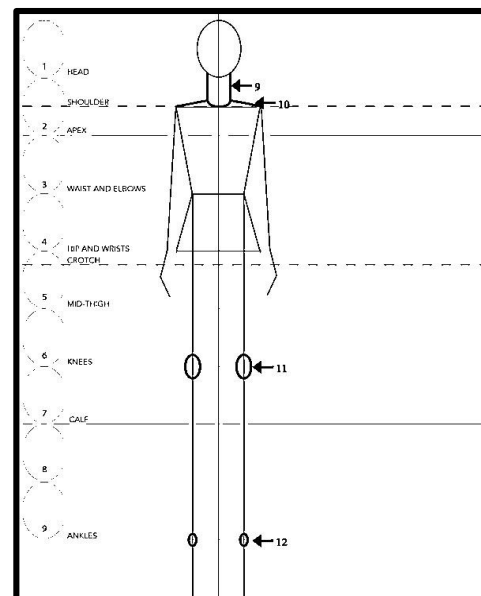

Fashion Figure

After the skeleton of the croquis is established, we can add muscular structure and shape. Take your time and draw lightly so you can erase easily.

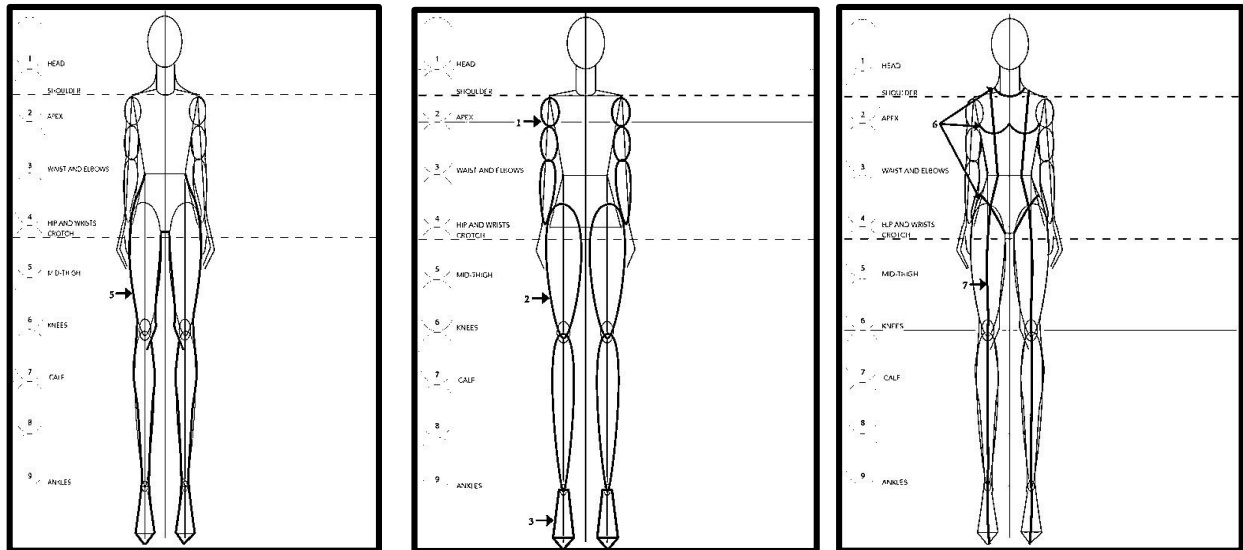

Activity-5.1:

❖ Draw a Front Pose of Fashion Croquis

Material required: Pencil, eraser, sharpener, sketch file and ruler

Draw Body Parts

Basic Human Anatomy

As a fashion designer you should always remember that clothes are made to be worn by real people. It is important, therefore, to gain some understanding of the structure and proportions of the human body. When drawing the fashion figure, it is important to know the standard proportions of the human form, as well as keeping in mind that people vary greatly in shape and size. Fashions change from culture to culture, and from decade to decade. Hands, thigh, knee, lower leg, upper torso, lower

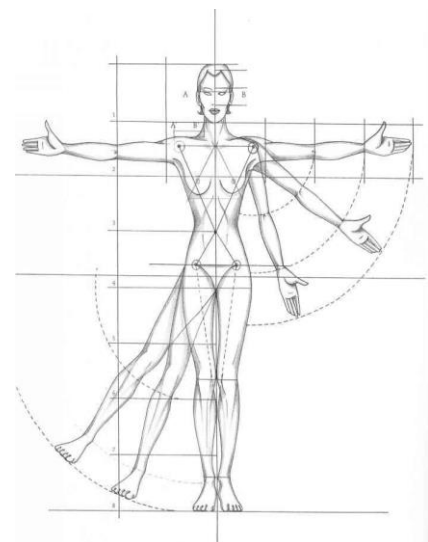

torso, lower arm, head, neck and shoulders upper arm. These basic parts can be manipulated to create different poses.

Point to Ponder!

Practice this by adjusting the parts of a wooden mannequin and drawing it at different angle.

Basics of Anatomy

Process of drawing head with different hairstyle

Great-looking hair is a fashion essential — even in a fashion illustration. If your drawing doesn't have natural yet exciting-looking hair, the hair will detract from the overall impact of your drawing. And unstylish hair can date your drawing in a nanosecond. As a trendy fashion illustrator, you definitely don't want people thinking your art is outdated.

- **Hair grows out of the head.** This point may sound obvious, but many people tend to draw hair that's contained within the original oval they sketch for the head. Hair grows out of and extends beyond the head.
- **Hair falls across the face and head.** Again, this fact may sound obvious, but many illustrators draw hair coming from the outside oval of the head. Hair grows from your forehead, temples, and the sides of your head, so it covers part of the oval that makes up the face.
- **The hairline follows the natural contours of the head.** A delicate oval head shape requires a hairline that's somewhat different from the hairline of a big guy with a square head.

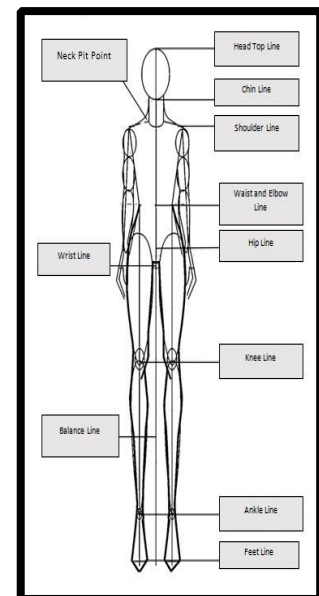
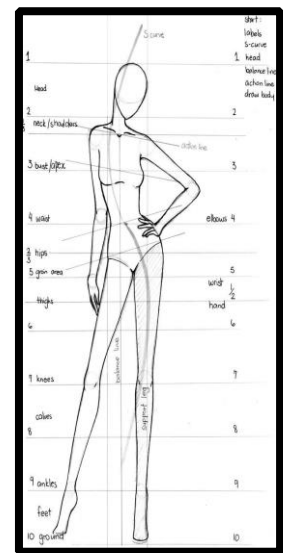

➤ Practice Step by Step Process of Drawing a Head

Step 1: Draw an Oval, Divide it in half horizontally and

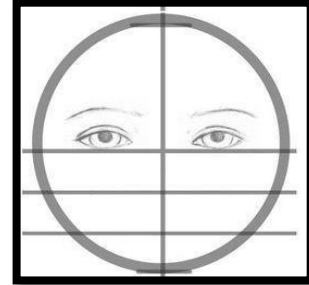

Step 2: Divide the bottom half into thirds.

Step 3: Draw the eyes just above the middleline.

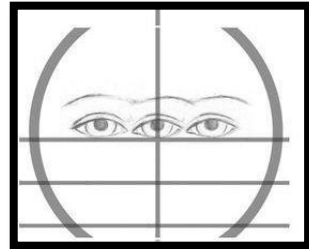

Step 4: Space them one eye width apart.

Step 5: Draw the nose on second horizontal line.

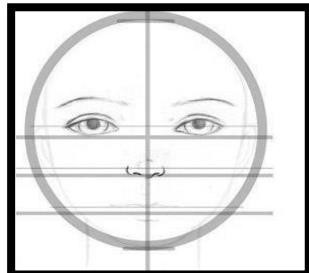

Step 6: Draw the lips on the third horizontal line

Step 7: Draw the face structure and hair style around it

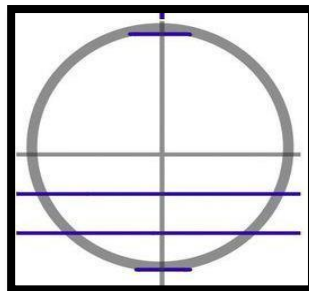
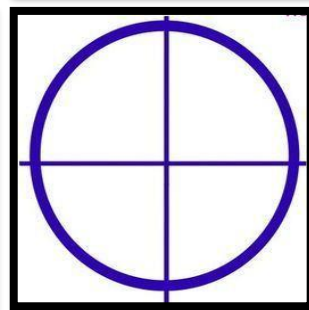
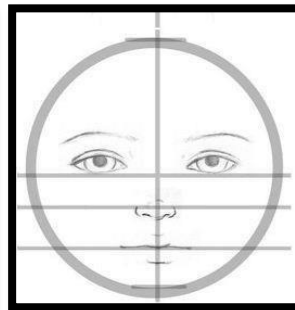
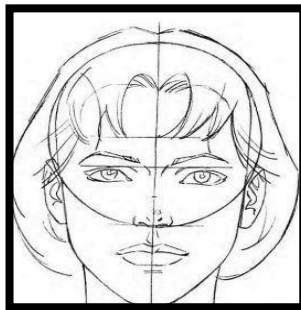

vertically.

➤ Practice Step by Step Process of Drawing a Head with Hairstyle

1) Define the General Shape

- a) Start by drawing the hairline and faceframing pieces
- b) Define the general shape or outline of the hair



2) Divide the shape

- a) Visualize the **rhythm**, or patterns of movement, of the hair.
- b) Divide the shape into large segments, based on the rhythm of the hair
- c) Add some strands into each segment to give the hair texture. Each strand should follow the movement pattern of the hair

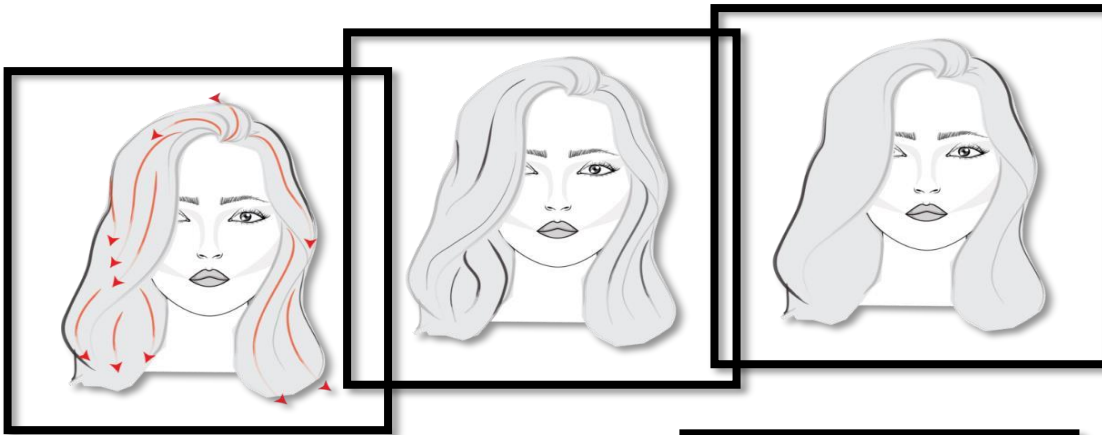

3) Add Dimension

- a) Add shadows to the roots, around hair segments, and background shapes
- b) Add highlights to the crown of the head and foreground shapes

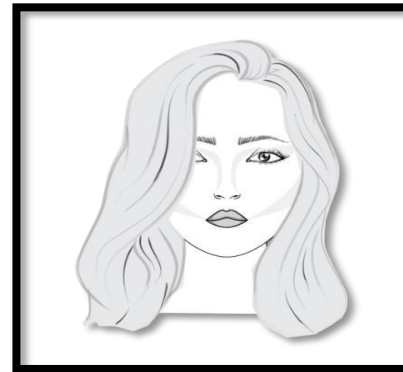

Do You Know?

Why it is really important to draw faces properly? A beautiful face will compliment an outfit greatly and can even evoke different emotions with viewers.

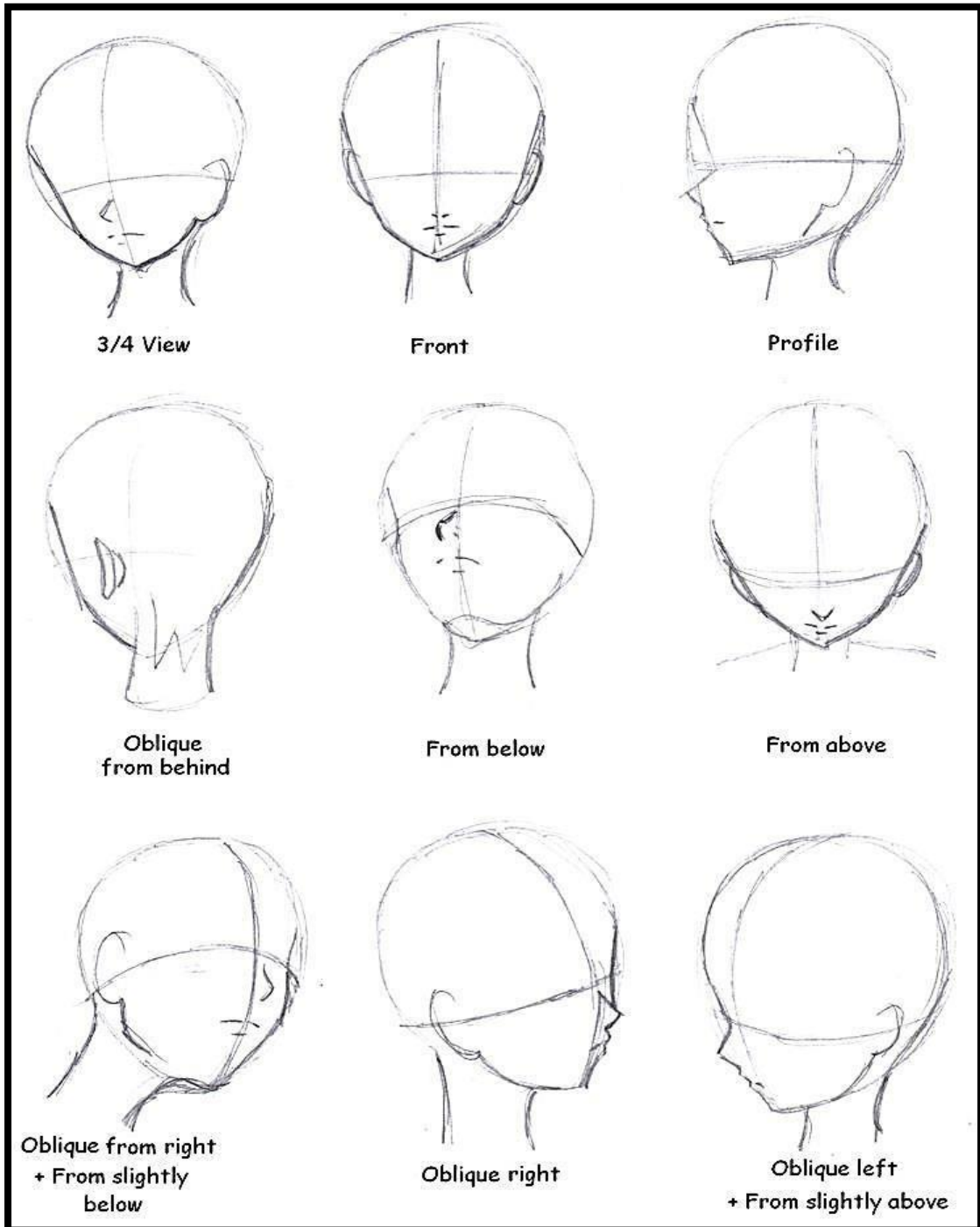

Activity:

- ❖ Practice different angles of heads as shown in the picture

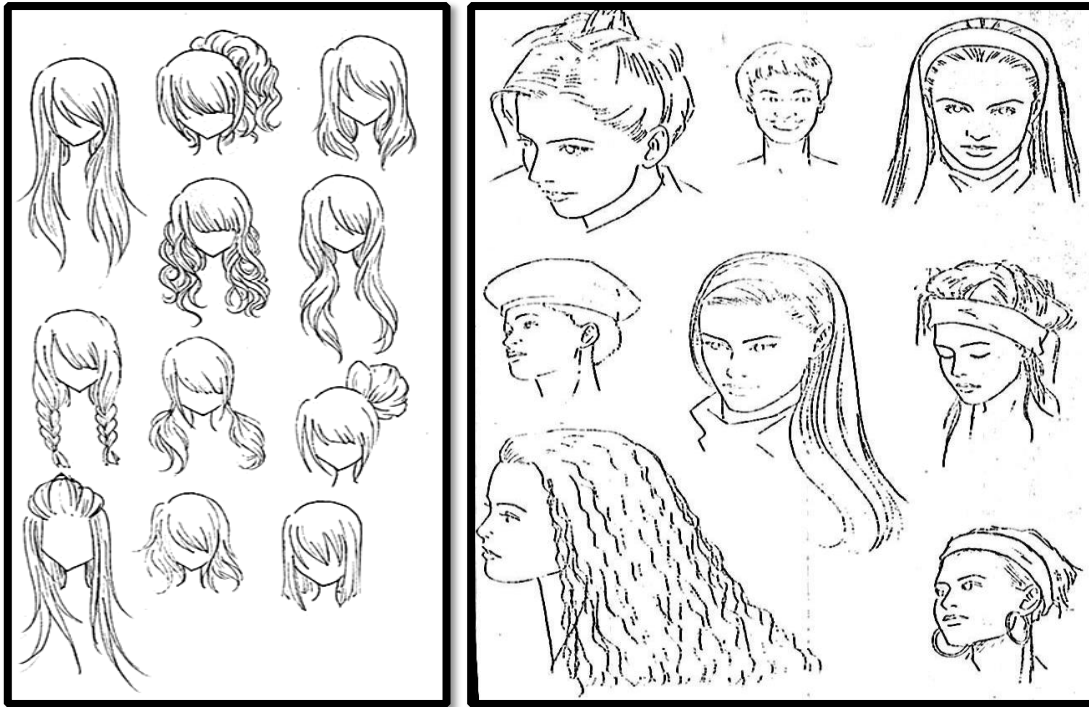
**Interesting information**

The right hairstyle not only beautifies the face but it also complements the outfit. The hairstyle also conveys character, style and social class. For example changing the hairstyle on a face can make it look glamorous or professional.

Do You Know?

The best way to draw hair is to first sketch a simple shape of the hairstyle just outlining the edges. After that you add some shape and layers to the hair and then at the end add details such as fine lines and some hair flying over the edges, darker spots in the partings and so on.

Activity:

- ❖ Practice different hairstyles as shown in the pictures

Process of drawing hand

Drawing the hands right is essential for a good-looking fashion sketch and illustration. This step-by-step tutorial will help you understand the basics of drawing hands and will show you how to create unique and interesting hands positions for your models ➤ **How to draw hands in 8**

steps:

- Step 1: Wrist and hand base
- Step 2: The thumb
- Step 3: Big knuckles
- Step 4: Fingers guideline
- Step 5: Middle knuckles
- Step 6: Draw the fingertips
- Step 7: Finish the outlines
- Step 8: Details

Step 1: Wrist and hand base

Make sure that the palm shape is longer than wider – hands in fashion sketches are long and delicate.

Step 2: The Thumb

Draw a guideline for the thumb. This line should start a bit below the top of the trapezoid and end below its base. Try not to draw the thumb too close or too far away from the palm.

Step 3: Big knuckles

Transform the palm base: lift the corner next to the thumb down and the corner away from the thumb up. Draw 4 circles over the new line

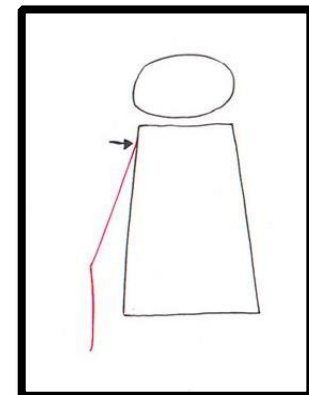
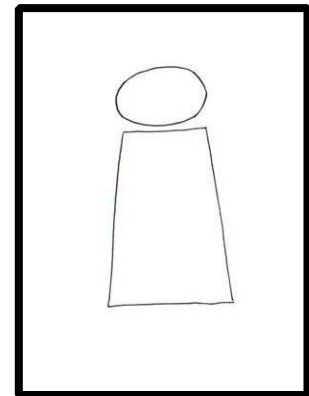

to indicate the knuckles. They should fill the palm width from one end to another. The knuckles will be always inclined from the thumb towards the little finger

Step 4: Fingers guideline

To mark the fingers draw inverted trapezoid under the knuckles. This one should be the same size and the palm, but the bottom end will be **heavily bent** (almost like a triangle).

The palm + fingers length is about the same as the face of your model.

Step 5: Middle knuckles

Starting from the big knuckles draw 4 straight lines to mark the fingers. Make sure they fit in the narrowed trapezoid shape and that the **little finger is shorter than the index** finger. The middle finger should be the longest one. Find the halfway of the finger lines and draw 4 circles to indicate the middle knuckles. Note that they are not aligned, but rather **placed on a curve**

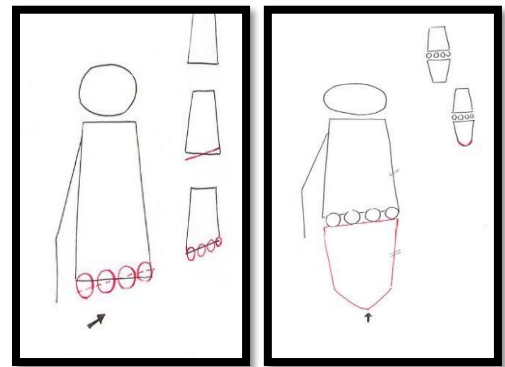

Step 6: Draw the fingertips

The fingertips are one of the trickiest parts of drawing the hands. Make sure that they look like the **letter “U”** and are not spiky or too thin. The same applies to the thumb. Double-check if all the fingers are with different lengths and the thumb reaches just below the big knuckles. Mark the half of the distance between the fingertips and the middle knuckles. This is the place for the little knuckles.

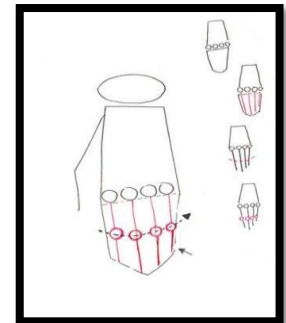

Step 7: Finish the outline

One of the things you should keep in mind is to stop the line every time you reach a knuckle (even the little knuckles that we marked only via a curved line). Also, it is important to draw the joint between the fingers

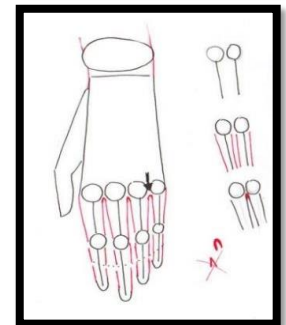

nically curved, not pointy. This joint is right next to the big knuckles.

Erase all the unnecessary lines and add the details. Note that only half of the thumb fingernail is visible because it's twisted to the side. Always mind the little gap between the finger outlines and the nails

Step8: Details

Do You Know?

Drawing the hands right is essential for a goodlooking fashion sketch and illustration.

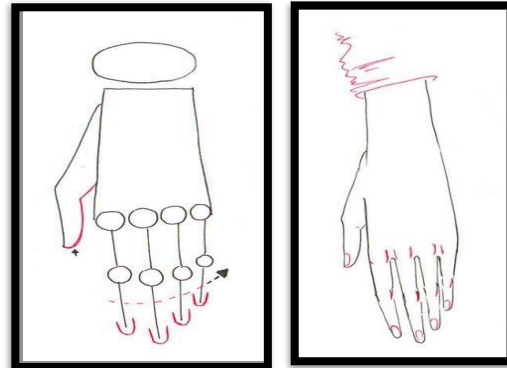

Activity:

❖ Practice different angles of Hands as shown in the picture

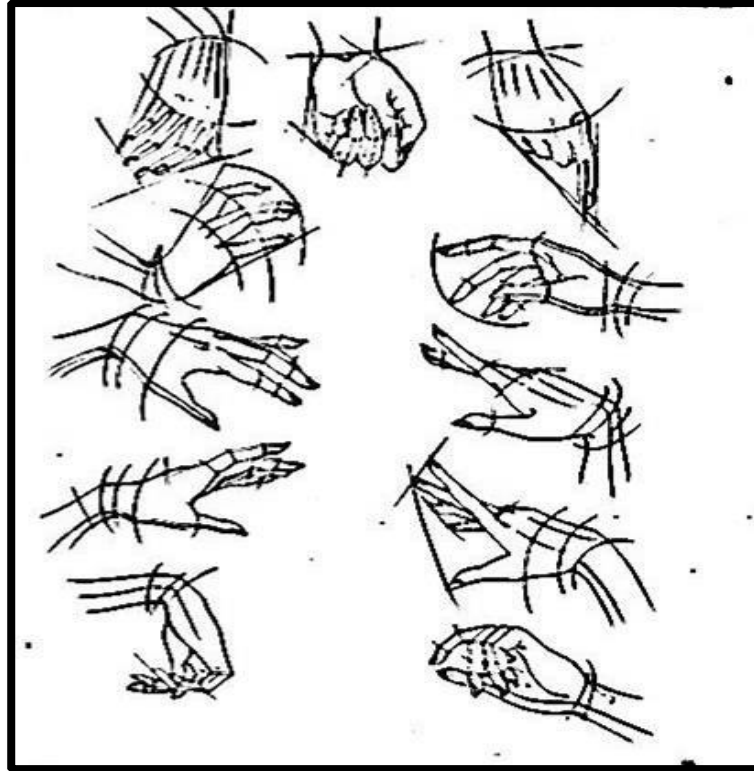

2.4 The process of drawing arms

Understanding how to properly draw the arms and the legs can dramatically improve your fashion sketches and give you a big advantage in the presentation of your designs.

➤ How to draw arms in 6 simple steps:

- Step 1: Draw the guidelines
- Step 2: Begin drawing the arms
- Step 3: Draw the elbow and the wrist
- Step 4: Draw the arms
- Step 5: More realistic arms
- Step 6: Adding the details

Step 1: Draw the guidelines

Mark the shoulders with circles. Add a center to each circle and pull horizontal guidelines. One where the waistline is and one at pelvis level. These are needed to determine where to place the elbow and the wrist. The guidelines will help you find the exact length of the arms even when they are not in a relaxed position. The arm and the forearm are always more or less the same length.

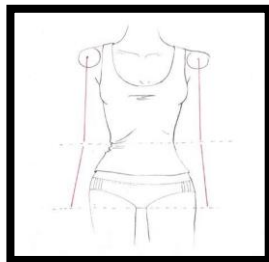
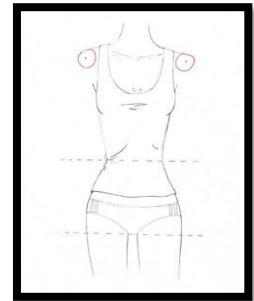

Step 2: Begin drawing the arms

Once you have marks to guide you, it's time to add straight lines to indicate the direction of the arms. Start from the center point of the shoulders. You can play and change those lines however you want, as long as you keep the proportions.

Step 3: Draw the elbow and the wrist

Having the size of the shoulder circle in mind, draw a smaller one for the elbow and another, even smaller, for the wrist. Be careful with the sizes- the arm should taper gradually. Use the guidelines you've already set to place the circles correctly. Draw an ellipse below the wrist circle to indicate the hand.

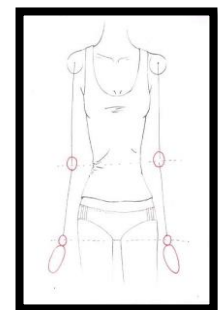

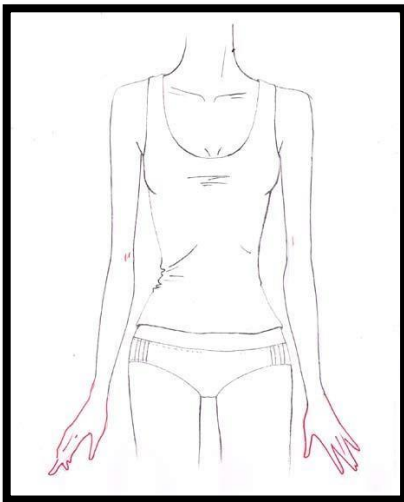
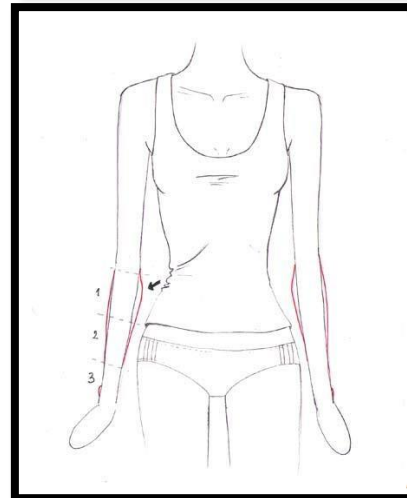
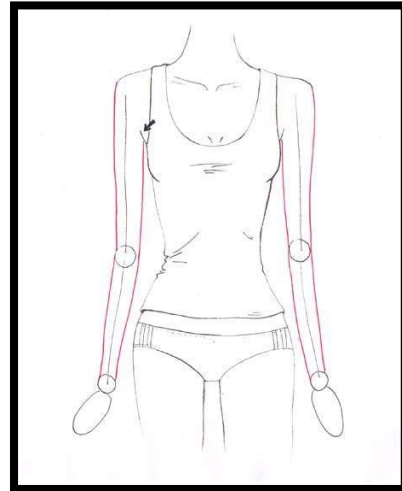
Step 4: Draw the arms**Step 6: Adding the details**

Add tiny dashes to indicate where the arm is contracting and draw the hands. Nothing more is needed.

Activity:

- ❖ Practice different angles of Arms as shown in the picture

Connect via straight lines the shoulder, the elbow, and the wrist circles. Notice the arrow? It shows where the arm should begin from so it doesn't look separated from the torso in a weird way.

Step 5: More realistic arms

If you leave the arm drawn like this it won't look believable. **Separate** the forearm in 3 equal parts. In the section closest to the elbow add some volume (more to the inner side and less to the outer). Blend gradually with the second section and leave the 3rd section the way it is. You can also hint at the knuckles of the outer side of the wrist.

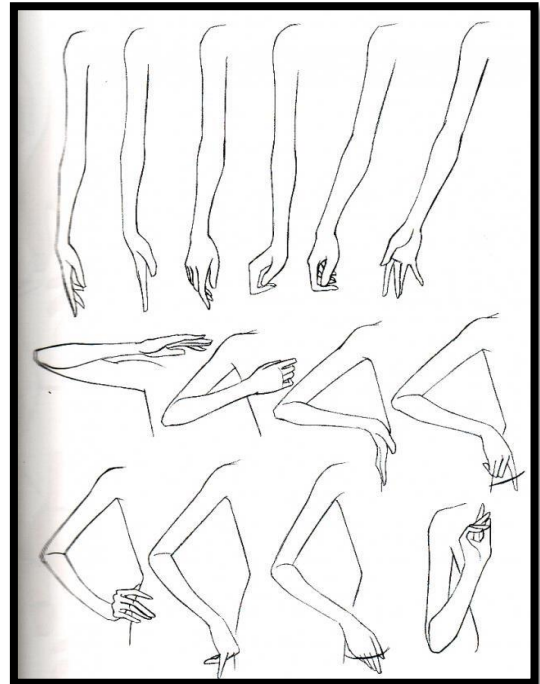

The process of drawing feet

Drawing feet can be difficult. With a padded bony heel, a long, arched set of metatarsals and flexible toes, the human foot is made up of a lot of varied elements, and it may seem like a challenge to put all these different parts together.

But like any other subject, the foot can be broken down into different forms before the details are added, no matter what perspective you approach it from.

1. Top plane

When viewed from above the plane of the top of the foot slopes away from the ankle down to the toes. Draw the overall shape that the toes will fit in first, and then divide that space up with lines between the toes.

2. Inside plane

The inside plane of the foot is approximately triangular, running from the ankle to the big toe

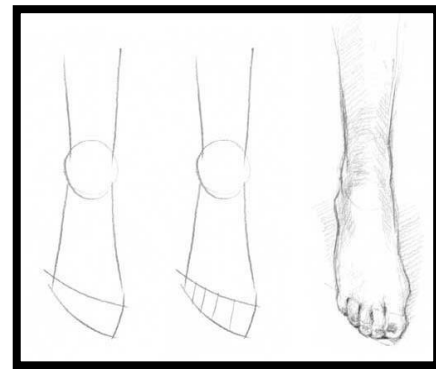

and heel. Use a rounded shape to establish the positions of the heel and ankle; the relationship between them is important for the stability of the figure.

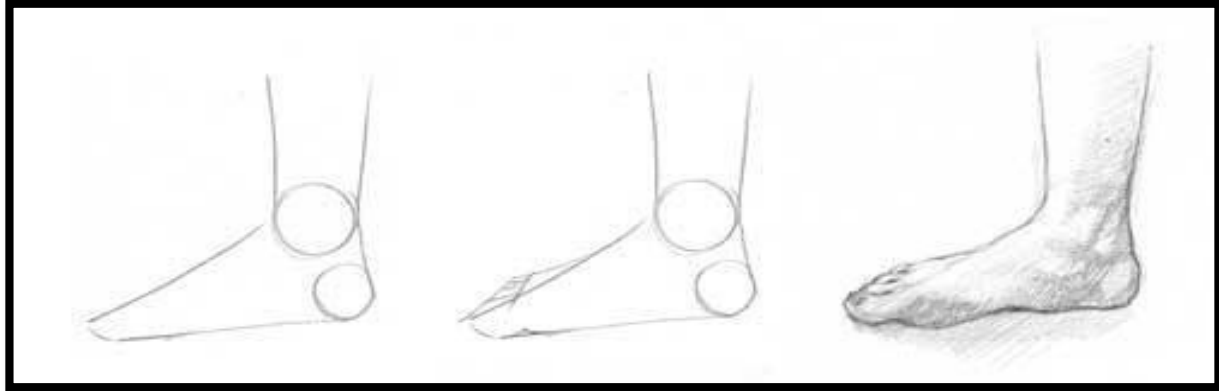

3. Underside

The underside of the foot is the kind of shape you see imprinted on the sand on beaches, the curves of this plane are more pronounced although it will still fit within a broad triangle

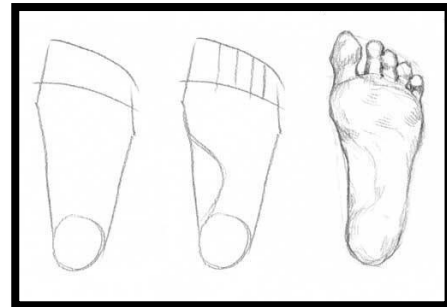

4. Angled views

You'll rarely see any single plane exclusively. Use the idea of the planes of the foot to break a complex shape down into simple elements before developing the foot drawing to more closely reflect what you see.

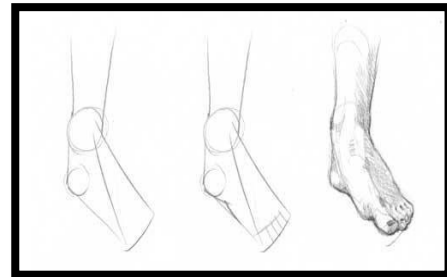

5. Back of the foot

The calf muscles taper to the Achilles tendon, and that in turn creates a hard edge on the back of the foot as it connects to the heel. You can see the ankle protruding out to each side and the foot sticking out in front.

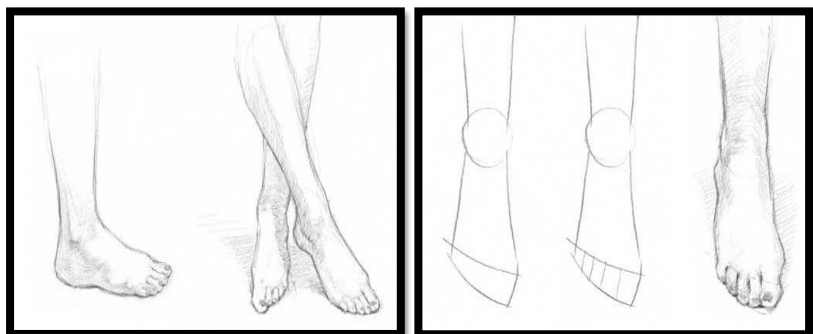

Activity**❖ Draw Feet without Model****Key Points**

Basics of Fashion Drawing/Illustration

The process of drawing basic 9Head fashion figure/Croquis

The process of drawing basic 10Head fashion figure/Croquis The
basic human anatomy

The process of drawing head with different hairstyles

The process of drawing hands

The process of drawing arms

The process of drawing feet

Web links:

<https://design.tutsplus.com/tutorials/human-anatomy-fundamentals-how-to-draw-fee--cms-21733>

<https://www.amikosimonetti.com/life/drawing-the-fashion-figure-with-9heads-proportion-part-1>

<https://www.fashionistasketch.com/draw-fashion-croquis/#comments>

Exercises

Tick (✓) the correct answer

1. **Fashion illustration uses how many heads for the construction**
 - a) 6 heads
 - b) 4 heads
 - c) 9 heads
 - d) 11 heads
2. **Drawing the face is important why**
 - a) It is good to have a face
 - b) It is not needed
 - c) The face complements the outfit.
 - d) It is enjoyable to draw a face.
3. **How do we draw hair?**
 - a) By drawing an oval
 - b) No need to draw it.
 - c) The hair covers part of the face and flows out ,we start by making an outline then drawing strands
 - d) The hair strands are drawn solid and rendered without any lights and darks.
4. **What is a fashion croqui?**
 - a) A Fashion illustration without clothes.
 - b) A complete illustration.
 - c) A finished garment
 - d) A quick sketch.
5. **Drawing hands is ----- for a fashion illustration**
 - a) Useless
 - b) Essential
 - c) Not important
 - d) Not needed

6. Illustration started from the

- a) 2000s
- b) 1980s
- c) 1500s
- d) 1600s.

7. Who is a fashion illustrator?

- a) An artist who makes a sketch.
- b) A designer who draws a pattern
- c) A designer who makes a Croquis and draws detailed clothing with accessories.
- d) A designer who designs clothes.

Constructed Response Question

Hair illustration is very important for fashion illustration. Two images are given for hair below. Which image shows the correct way to depict hair?

a)



b)



Elaborate which is the right image and draw an example of the right way of depicting hair as learnt in this chapter.

Write Short Answers

1. How many steps are needed to construct arms?
2. Explain the process of drawing hands in 2 lines.

3. How do we measure the correct distance between the eyes while drawing the face?
4. Why is understanding human anatomy important in fashion illustration?
5. Why is fashion important in our lives?
6. How do fashion designers brainstorm their ideas?
7. Is it necessary to draw a face in a fashion drawing?
8. Can a fashion drawing be a quick sketch or only a detailed drawing?
9. Is fashion a visual field or theoretical?
10. Can a skill be improved upon?

Project: Draw a Female Fashion Croquis

Required Materials:

Canson sheet or drawing paper, Pencil, Eraser, Water colors, Brush, Color pencils, 0.5 and 0.2 black pointer, Internet, Black chart paper, Scissors **Process:**

1. Draw feet and arms. The feet should be approximately the length of the head and shaped like a triangle. The figure's arms should be a little longer than they are in real life. Create the arms with tapered lines to the elbow and then again to the wrist. Finish with hands and fingers.
2. Draw the balance line. Draw a vertical centerline for the figure's center of balance. This line will start from the top of the head and extend to the bottom of the figure's legs.
3. Draw the pelvic area. Just below the middle of the balance line, draw a square to represent the pelvis.
4. Draw torso and shoulders. From the top corners of the pelvic square, draw two lines upward to create the torso.
5. Draw neck and head. The neck should be one-third of the shoulder width, and half the length of the head. Draw a circle for the head in proportion to the body.
6. Draw legs. The figure's legs should be approximately four times the length of the head created.
7. Draw feet and arms. The feet should be approximately the length of the head and shaped like a triangle. The figure's arms should be a little longer than they are in real life. Create the arms with tapered lines to the elbow and then again to the wrist. Finish with hands and fingers.
8. Render with watercolors and color pencils.
9. Draw details with black pointer.
10. Mount the finished illustration on the black chart paper.

Glossary

Accessories: decorative or fastening complementary pieces on a dress garment.

Analogous range: harmonious range created from two or three colors closely situated in the

Artificial fibers: fibers that come from natural elements but are subjected to industrial transformation processes.

Boutique: small clothing store. Casualwear: dress style that emphasizes comfort and personal expression.

Chromatic circle.

Collage: artistic technique consisting of creating a composition that includes elements of a diverse nature.

Color: refers to the hue or tone itself.

Complementary range: harmonious range formed by two complementary colors and their

Concept book: also called a thematic panel, a tool that helps give expression to the ideas a collection wants to transmit through images and key words.

Continuous fabric: method used to obtain cloth and knit fabrics.

Discontinuous fabric: method for obtaining non fabrics.

Fashion figure: two-dimensional representation of a look or garment.

Gadget: element with a specific purpose and function, practical and at the same time novel.

Haute couture: system of fashion production and communication that came into existence in the second half of the twentieth century, main objective of which is to custom dress women.

Interlining: hidden element that provides form and support in specific areas of a garment.

Knit fabric: cloth made up of loops of knit thread.

Length: meters per kilogram of a thread or fabric.

Monochromatic range: harmonious range obtained with a single color by varying its saturation and/or value.

Moulage: technique consisting in the creation of a three-dimensional design or pattern, molding the fabric directly onto the body of a model or sewing dummy.

Natural fibers: fibers made from animal, plant, or mineral components.

Nonfabrics: cloths produced from the compression of fabrics via heat, friction, or chemical products.

Pattern: geometric construction based on the measurements of the figure used as a model for producing garments.

Pret-a-porter: also called "ready to wear," mass production with the added value of "fashion."

Printing: process of transferring an image onto a textile.

Prototype: version of a garment as it will later appear at the point of sale.

Saturation: degree of intensity of a color.

Sketchbook: a notebook that reflects the creative process of a garment or collection of a designer.

Slog: log published on the Internet, updated periodically by its author or authors.

Streetwear: dress style characterized by a young urban aesthetic, based on elemental garments.

Synthetic fibers: fibers produced entirely from chemical products.

Tailoring: making, repairing, or alteration of men's garments.

Test garment: first sample of a garment, generally made with white or natural-colored fabric.

Thematic panel: see concept book.

Value: degree of brightness or darkness of a color.

Vintage clothing: quality clothes that are out of season and considered classic.

About the Author

Mohni Saif is a Director Academics for Faculty of Fashion & Textile Design @ Institute of Art, Design & Management. She completed his MFA from University of Punjab, College of Art& Design, Lahore. She has been attached to the field of Art & Design for more than twenty years with a passion to establish a sound basis for evolving Art & Design in Education. She is also a research scholar of” Education Leadership & Management “

She has been working with various companies and non governmental organizations to promote art at different levels in Pakistani society. She has been attached to design and deliver Art & Design, fashion & textile, interior design courses and workshops.

The learning and exposure that she got from Queensland University of Technology (QUT) Australia has been remarkable. She was exposed to the best VET practices in Australia to understand the harmony among all stakeholders in creating an exemplary demand driven TVET.

Furthermore, her contribution towards an effective TVET in Pakistan till date includes: writing several Art& Design Books. Conducting and participating in trainings for DACUMs formulation for multiple trades and sectors, and development of Competency Standards & Curriculum, Teaching Learning Material (TLM) and Assessment packages for several qualifications, building the soft skills & entrepreneurship among trainees.

قومی ترانہ

پاک سر زمین شاد باد! کشورِ حسین شاد باد!
تو نشانِ عزمِ عالی شان ارضِ پاکستان
مرکزِ یقین شاد باد!

پاک سر زمین کا نظام قوتِ اخوتِ عوام
قوم، ملک، سلطنت پائندہ تابندہ باد!
شاد باد منزلِ مراد!

پرچمِ ستارہ و ہلال رہبرِ ترقی و کمال
ترجمانِ ماضی، شانِ حال جانِ استقبال
سایہ خدائے ذوالجلال!



National Vocational & Technical Training Commission (NAVTTC)

Plot No.38, Sector H-9/4, Kirthar Road, Islamabad.

Tel: +92-51-9207518

Website: www.navttc.gov.pk